

UBA2024

Half-bridge power IC for CFL lamps

Rev. 03 — 16 October 2008

Product data sheet

1. General description

The UBA2024P is a high-voltage monolithic integrated circuit. The Integrated Circuit (IC) is designed for driving Compact Fluorescent Lamps (CFL) in a half-bridge configuration.

The IC features a soft start function, an adjustable internal oscillator and an internal drive function with a high-voltage level shifter for driving the half-bridge.

To guarantee an accurate 50 % duty cycle, the oscillator signal is passed through a divider before being fed to the output drivers.

2. Features

- Integrated half-bridge power transistors
- Integrated bootstrap diode
- Integrated low-voltage supply
- Adjustable oscillator frequency
- Maximum voltage of 550 V
- Minimum glow time control
- Soft start

3. Applications

- Driver for any kind of load in a half-bridge configuration
- Especially for electronically self-ballasted CFL for lamp currents up to 220 mA (RMS) under the restriction that the maximum junction temperature is not exceeded

4. Ordering information

Table 1. Ordering information

Type number	Package		Version
	Name	Description	
UBA2024P	DIP8	plastic dual in-line package; 8 leads (300 mil)	SOT97-1

5. Block diagram

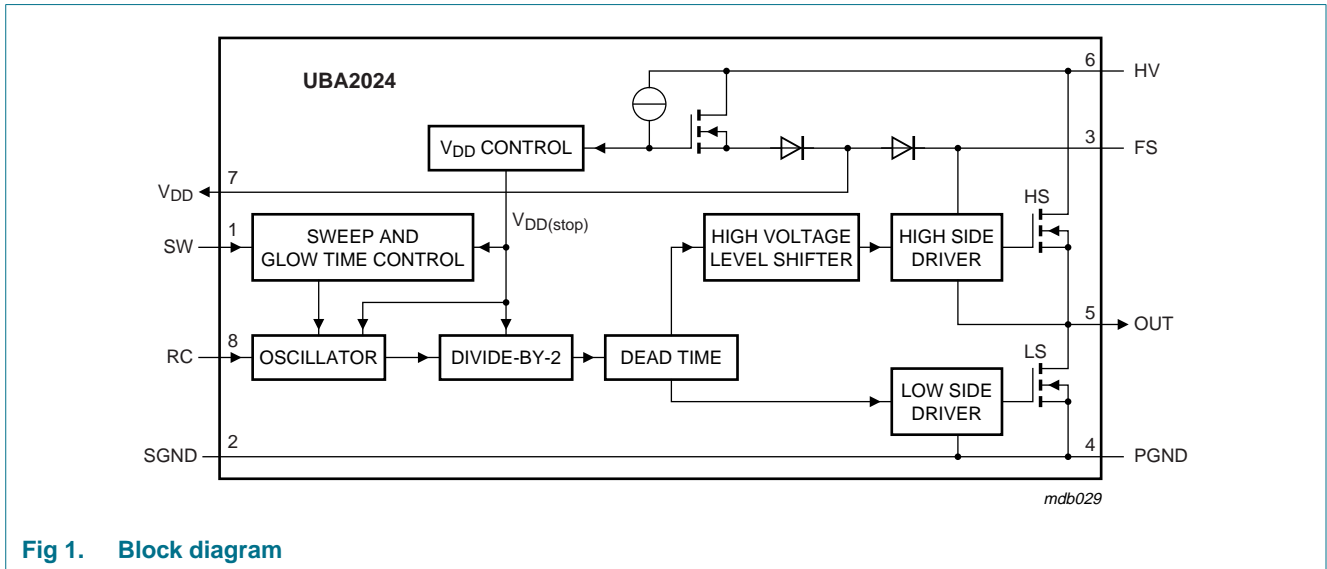

Fig 1. Block diagram

6. Pinning information

6.1 Pinning

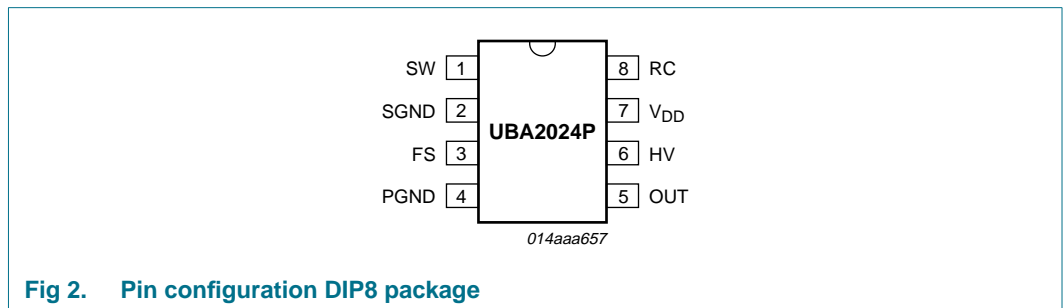

Fig 2. Pin configuration DIP8 package

6.2 Pin description

Table 2. Pin description

Symbol	Pin	Description
SW	1	sweep timing input
SGND	2	signal ground
FS	3	high-side floating supply output
PGND	4	power ground
OUT	5	half-bridge output
HV	6	high-voltage supply
V _{DD}	7	internal low-voltage supply output
RC	8	internal oscillator input

7. Functional description

7.1 Supply voltage

The UBA2024 is powered by a supply voltage applied to pin HV. The IC generates its own low supply voltage for the internal circuitry. Therefore an additional external low-voltage supply is not required.

7.2 Start-up state

With an increase of the supply voltage on pin HV, the IC enters the start-up state. In the start-up state the high-side power transistor is not conducting and the low-side power transistor is switched on. The internal circuit is reset and the capacitors on the bootstrap pin FS and low-voltage supply pin V_{DD} are charged. Pins RC and SW are switched to ground. The start-up state is defined until V_{DD} = V_{DD(start)}.

7.3 Sweep mode

The IC enters the sweep mode at the moment the voltage on pin V_{DD} > V_{DD(start)}. The capacitor on pin SW is charged by I_{sweep} and the half-bridge circuit starts oscillating. The circuit enters the start-up state again when the voltage on pin V_{DD} < V_{DD(stop)}.

7.4 Reset

A DC reset circuit is incorporated in the high-side driver. The high-side transistor is switched off when the voltage on pin FS is below the high-side lockout voltage V_{FS(lock)}.

7.5 Oscillation

The oscillation is based upon the 555-timer function. With the external resistor R_{OSC} and capacitor C_{OSC} (see [Figure 3](#)) a self oscillating circuit is made, where R_{OSC} and C_{OSC} determine the oscillating frequency.

To realize an accurate 50 % duty cycle, an internal divider is used. Due to the presence of the divider, the bridge frequency is half the oscillator frequency.

The output voltage of the bridge will change at the falling edge of the signal on pin RC. The design equation for the half-bridge frequency is:

$$f_{osc} = \frac{I}{k \times R_{OSC} \times C_{OSC}}$$

An overview of the oscillator signal, internal LS and HS drive signals and the output is given in [Figure 3](#).

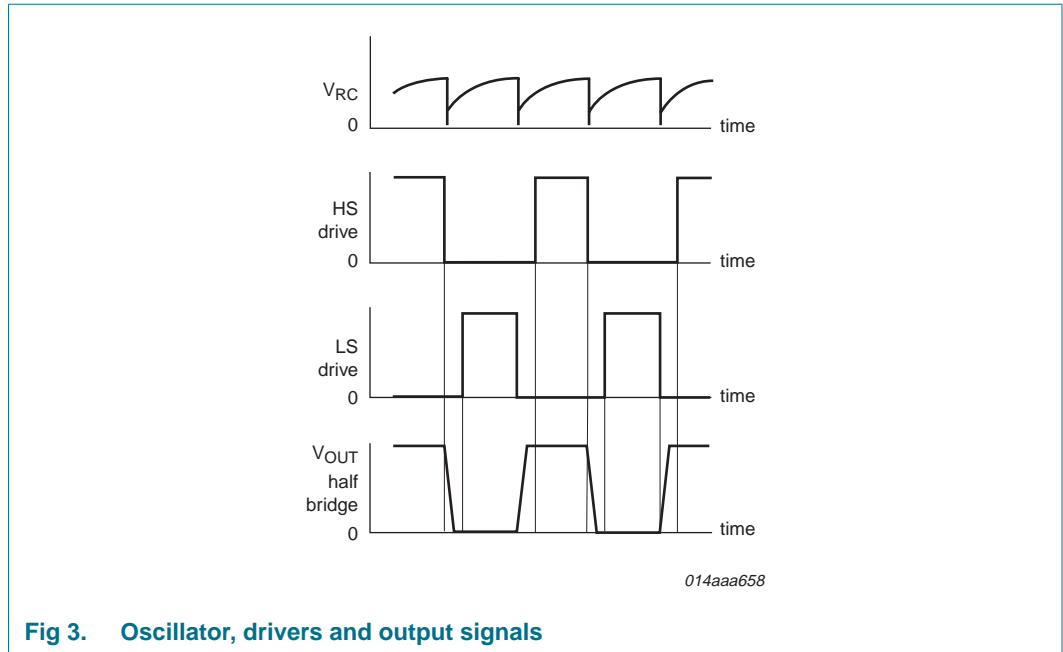

Fig 3. Oscillator, drivers and output signals

When entering the sweep mode, the oscillator starts at 2.5 times the nominal bridge frequency and sweeps down to the nominal bridge frequency f_{nom} ; see [Figure 4](#). During this continuously decreasing of the frequency, the circuit approaches the resonance frequency of the load. This causes a high voltage across the load, which ignites the lamp.

The sweep time t_{sweep} is determined by the charge current $I_{ch(sw)}$ and the external capacitor C_{SW} . The sweep to resonance time should be much larger than the settling time of the supply voltage on pin HV to guarantee that the full high-voltage is present at the moment of ignition.

The amplitude of the RC oscillator is equal to the minimum value of $V_{RC(h)}$ and $V_{SW} + 0.4 \times V_{RC(h)}$.

During the sweep time a current is flowing through the lamp electrodes for preheating the filaments.

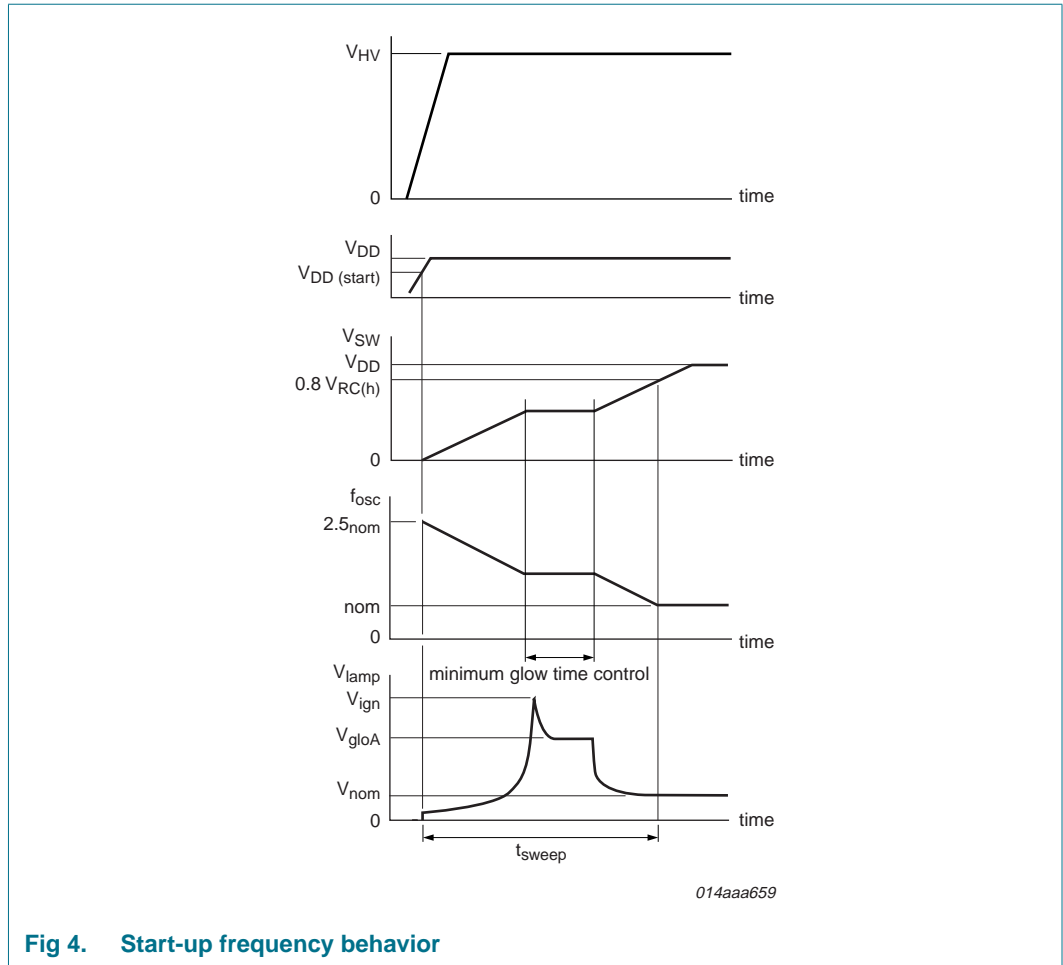

Fig 4. Start-up frequency behavior

7.6 Glow time control

The drawback of cold-started CFL lamps is its inherent glow time which reduces the switching lifetime of the electrodes (lamp). To make this glow phase as short as possible, the maximum power is given to the lamp during the glow time via a special control; see [Figure 4](#).

7.7 Non-overlap time

The non-overlap time is defined as the time that both MOSFETs are not conducting. The non-overlap time is internally fixed.

8. Limiting values

Table 3. Limiting values

In accordance with the Absolute Maximum Rating System (IEC 60134).

Symbol	Parameter	Conditions	Min	Max	Unit
V _{HV}	high-voltage supply voltage	normal operation	-	373	V
		mains transients during 0.5 s	-	550	V
V _{FS}	floating supply voltage		V _{HV}	V _{HV} + 14	V
V _{DD}	low-voltage output supply voltage	DC supply	0	14	V
I _{DD}	low-voltage output supply current	peak value is internally limited; T _{amb} = 25 °C	0	5	mA
V _{PGND}	power ground voltage	referenced to SGND	-1	+1	V
V _{I(RC)}	internal oscillator input voltage on pin RC	I _{i(RC)} < 1 mA	0	V _{DD}	V
V _{I(SW)}	sweep time input voltage on pin SW	I _{i(SW)} < 1 mA	0	V _{DD}	V
SR	slew rate output on pin OUT	repetitive	-4	+4	V/ns
T _j	junction temperature		-40	+150	°C
T _{amb}	ambient temperature		-40	+150	°C
T _{stg}	storage temperature		-55	+150	°C
V _{esd}	electrostatic discharge voltage	human body model:	[1]		
		pins HV and V _{DD}	-	1000	V
		pins SW, RC, FS, and OUT	-	2500	V
		machine model:	[2]		
		pin FS	-	200	V
		pins HV, V _{DD} , SW, RC, and OUT	-	250	V

[1] In accordance with the Human Body Model (HBM): equivalent to discharging a 100 pF capacitor through a 1.5 kΩ series resistor.

[2] In accordance with the Machine Model (MM): equivalent to discharging a 200 pF capacitor through a 1.5 kΩ series resistor and a 0.75 μH inductor.

9. Thermal characteristics

Table 4. Thermal characteristics

Symbol	Parameter	Conditions	Typ	Unit
$R_{th(j-a)}$	thermal resistance from junction to ambient	in free air	[1]	95 K/W
$R_{th(j-c)}$	thermal resistance from junction to case	in free air	[1]	16 K/W

[1] In accordance with IEC 60747-1

10. Characteristics

Table 5. Characteristics

$T_j = 25\text{ °C}$; all voltages are measured with respect to SGND; positive currents flow into the IC.

Symbol	Parameter	Conditions	Min	Typ	Max	Unit
High-voltage supply						
V_{HV}	high-voltage supply voltage	$t < 0.5\text{ s}$; $I_{HV} < 30\text{ mA}$	0	-	550	V
V_{FS}	floating supply voltage	$t < 0.5\text{ s}$; $I_{HV} < 30\text{ mA}$	0	-	564	V
Low-voltage supply						
V_{DD}	low-voltage output supply voltage	$V_{HV} = 100\text{ V}$; $R_{OSC} = \infty$; $V_{SW} = V_{DD}$; $V_{RC} = 0\text{ V}$	11.7	12.5	13.3	V
Start-up state						
I_{HV}	high-voltage supply current	$V_{HV} = 100\text{ V}$; $R_{OSC} = \infty$; $V_{SW} = V_{DD}$; $V_{RC} = 0\text{ V}$	-	-	0.39	mA
$V_{DD(start)}$	start of oscillation voltage		10	11	12	V
$V_{DD(stop)}$	stop of oscillation voltage		8	8.5	9	V
$V_{DD(hys)}$	start-stop hysteresis voltage		2	2.5	3	V
Output stage						
$R_{HS(on)}$	HS transistor on-resistance	$V_{HV} = 310\text{ V}$; $I_d = 100\text{ mA}$	-	9.7	11	Ω
$R_{LS(on)}$	LS transistor on-resistance	$I_d = 100\text{ mA}$	-	8.5	9.4	Ω
$V_{HS(d)}$	HS body diode forward voltage	$I_f = 200\text{ mA}$	1.4	1.8	2.2	V
$V_{LS(d)}$	LS body diode forward voltage	$I_f = 200\text{ mA}$	1.2	1.6	2.0	V
$I_{HS(sat)}$	HS transistor saturation current	$V_{ds} = 30\text{ V}$; $T_j \leq 125\text{ °C}$; $V_{HV} = 310\text{ V}$	900	-	-	mA
$I_{LS(sat)}$	LS transistor saturation current	$V_{ds} = 30\text{ V}$; $T_j \leq 125\text{ °C}$	900	-	-	mA
$I_{O(max)}$	maximum output current	RMS value	-	-	220	mA
V_{boot}	bootstrap diode drop voltage	$I_f = 1\text{ mA}$	0.7	1.0	1.3	V
t_{no}	non-overlap time		1	1.35	1.7	μs
$V_{FS(lock)}$	floating supply lockout voltage		3.6	4.2	4.8	V
I_{FS}	floating supply current	$V_{HV} = 310\text{ V}$; $V_{FS} = 12.2\text{ V}$	10	14	18	μA

Table 5. Characteristics ...continued

$T_j = 25\text{ }^\circ\text{C}$; all voltages are measured with respect to SGND; positive currents flow into the IC.

Symbol	Parameter	Conditions	Min	Typ	Max	Unit
Internal oscillator						
f_{osc}	frequency range bridge oscillator	$V_{SW} = V_{DD}$	-	-	60	kHz
$f_{osc(nom)}$	nominal frequency bridge oscillator	$R_{OSC} = 100\text{ k}\Omega$; $C_{OSC} = 220\text{ pF}$; $V_{SW} = V_{DD}$	40.05	41.32	42.68	kHz
$\Delta f_{osc(nom)}$	bridge oscillator frequency variation with temperature	$R_{OSC} = 100\text{ k}\Omega$; $C_{OSC} = 220\text{ pF}$; $\Delta T = -20\text{ to }+150\text{ }^\circ\text{C}$	-	2	-	%
k_h	high-level trip point factor		0.382	0.395	0.408	
$V_{RC(h)}$	high-level trip point voltage on pin RC	$V_{RC(h)} = k_h \times V_{DD}$	4.58	4.94	5.29	V
k_l	low-level trip point factor		0.030	0.033	0.036	
$V_{RC(low)}$	low-level trip point voltage on pin RC	$V_{RC(l)} = k_l \times V_{DD}$	0.367	0.413	0.458	V
K_{osc}	oscillator constant	$R_{OSC} = 100\text{ k}\Omega$; $C_{OSC} = 220\text{ pF}$	1.065	1.1	1.35	V
Sweep function						
$I_{ch(sw)}$	charge current for sweep	$V_{SW} = 0\text{ V}$	215	280	345	nA
t_{sweep}	sweep time	$C_{SW} = 33\text{ nF}$; $V_{DD} = 12.2\text{ V}$	0.28	0.35	0.45	s

11. Application information

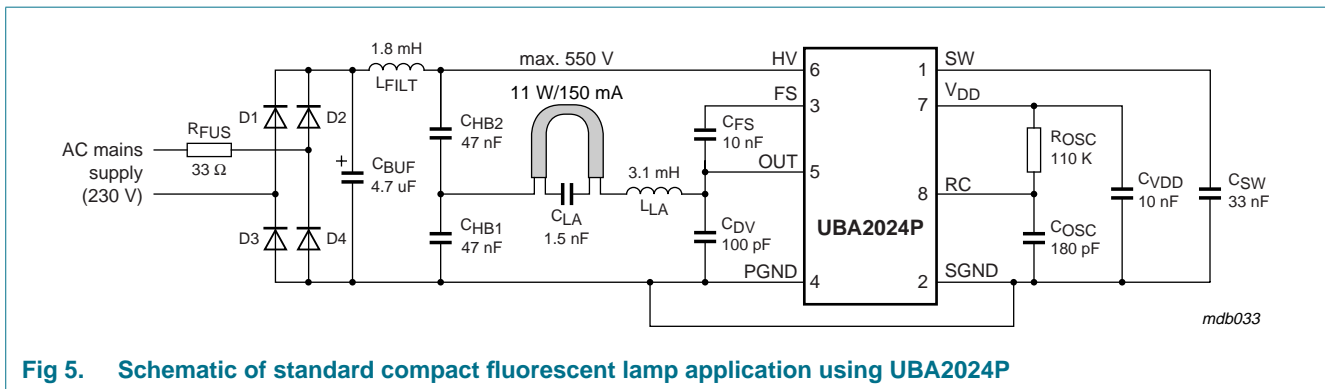

12. Package outline

DIP8: plastic dual in-line package; 8 leads (300 mil)

SOT97-1

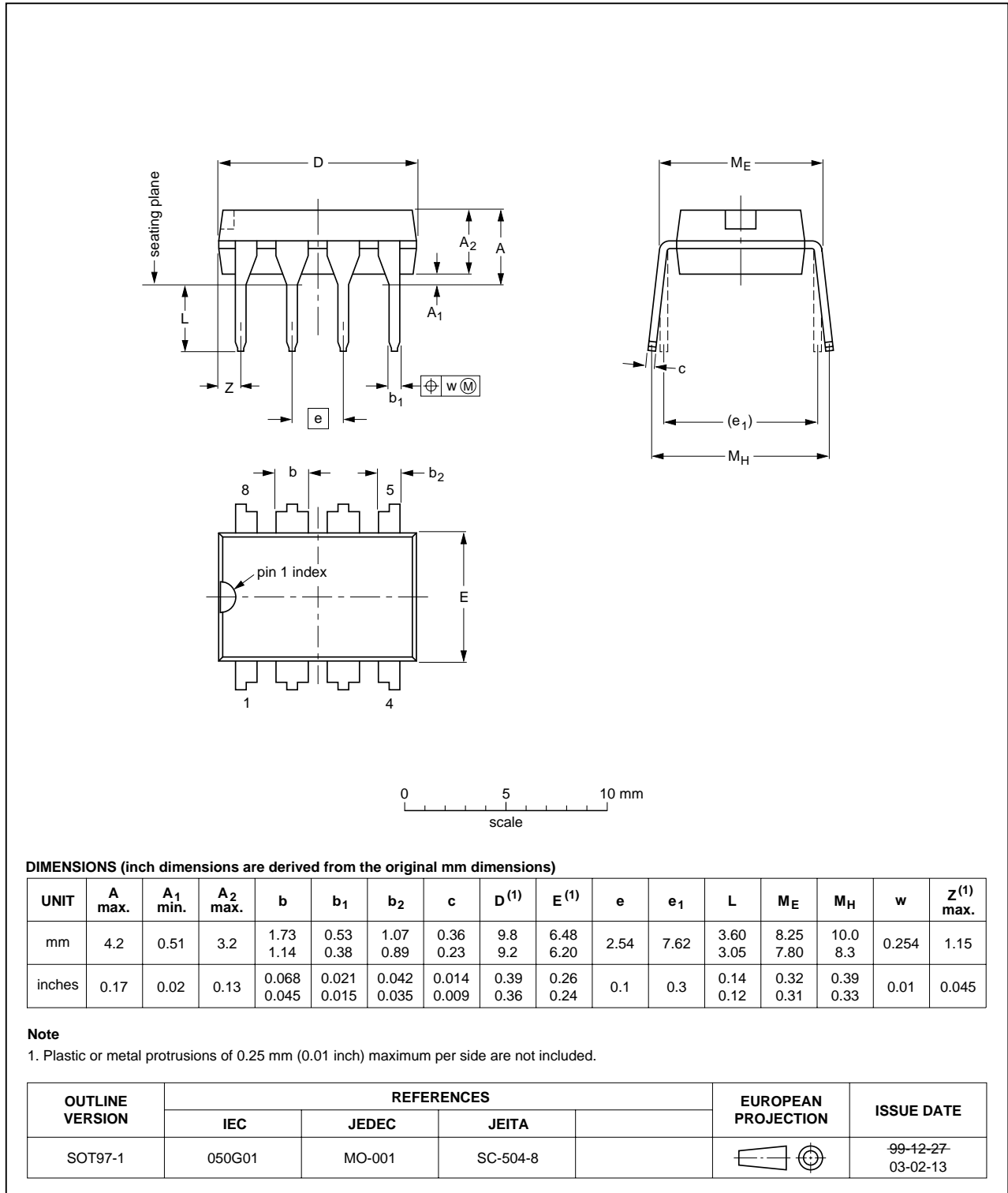

Fig 6. Package outline SOT97-1

13. Revision history

Table 6. Revision history

Document ID	Release date	Data sheet status	Change notice	Supersedes
UBA2024_3	20081016	Product data sheet	-	UBA2024_2
Modifications:		<ul style="list-style-type: none">The format of this data sheet has been redesigned to comply with the new identity guidelines of NXP Semiconductors.Legal texts have been adapted to the new company name where appropriate.		
UBA2024_2	040203	Product data sheet	-	UBA2024_1
UBA2024_1	030813	Product data sheet	-	-

14. Legal information

14.1 Data sheet status

Document status ^{[1][2]}	Product status ^[3]	Definition
Objective [short] data sheet	Development	This document contains data from the objective specification for product development.
Preliminary [short] data sheet	Qualification	This document contains data from the preliminary specification.
Product [short] data sheet	Production	This document contains the product specification.

[1] Please consult the most recently issued document before initiating or completing a design.

[2] The term 'short data sheet' is explained in section "Definitions".

[3] The product status of device(s) described in this document may have changed since this document was published and may differ in case of multiple devices. The latest product status information is available on the Internet at URL <http://www.nxp.com>.

14.2 Definitions

Draft — The document is a draft version only. The content is still under internal review and subject to formal approval, which may result in modifications or additions. NXP Semiconductors does not give any representations or warranties as to the accuracy or completeness of information included herein and shall have no liability for the consequences of use of such information.

Short data sheet — A short data sheet is an extract from a full data sheet with the same product type number(s) and title. A short data sheet is intended for quick reference only and should not be relied upon to contain detailed and full information. For detailed and full information see the relevant full data sheet, which is available on request via the local NXP Semiconductors sales office. In case of any inconsistency or conflict with the short data sheet, the full data sheet shall prevail.

14.3 Disclaimers

General — Information in this document is believed to be accurate and reliable. However, NXP Semiconductors does not give any representations or warranties, expressed or implied, as to the accuracy or completeness of such information and shall have no liability for the consequences of use of such information.

Right to make changes — NXP Semiconductors reserves the right to make changes to information published in this document, including without limitation specifications and product descriptions, at any time and without notice. This document supersedes and replaces all information supplied prior to the publication hereof.

Suitability for use — NXP Semiconductors products are not designed, authorized or warranted to be suitable for use in medical, military, aircraft, space or life support equipment, nor in applications where failure or malfunction of an NXP Semiconductors product can reasonably be expected to result in personal injury, death or severe property or environmental

damage. NXP Semiconductors accepts no liability for inclusion and/or use of NXP Semiconductors products in such equipment or applications and therefore such inclusion and/or use is at the customer's own risk.

Applications — Applications that are described herein for any of these products are for illustrative purposes only. NXP Semiconductors makes no representation or warranty that such applications will be suitable for the specified use without further testing or modification.

Quick reference data — The Quick reference data is an extract of the product data given in the Limiting values and Characteristics sections of this document, and as such is not complete, exhaustive or legally binding.

Limiting values — Stress above one or more limiting values (as defined in the Absolute Maximum Ratings System of IEC 60134) may cause permanent damage to the device. Limiting values are stress ratings only and operation of the device at these or any other conditions above those given in the Characteristics sections of this document is not implied. Exposure to limiting values for extended periods may affect device reliability.

Terms and conditions of sale — NXP Semiconductors products are sold subject to the general terms and conditions of commercial sale, as published at <http://www.nxp.com/profile/terms>, including those pertaining to warranty, intellectual property rights infringement and limitation of liability, unless explicitly otherwise agreed to in writing by NXP Semiconductors. In case of any inconsistency or conflict between information in this document and such terms and conditions, the latter will prevail.

No offer to sell or license — Nothing in this document may be interpreted or construed as an offer to sell products that is open for acceptance or the grant, conveyance or implication of any license under any copyrights, patents or other industrial or intellectual property rights.

14.4 Trademarks

Notice: All referenced brands, product names, service names and trademarks are the property of their respective owners.

15. Contact information

For more information, please visit: <http://www.nxp.com>

For sales office addresses, please send an email to: salesaddresses@nxp.com

16. Contents

1 General description 1

2 Features 1

3 Applications 1

4 Ordering information 1

5 Block diagram 2

6 Pinning information 2

6.1 Pinning 2

6.2 Pin description 2

7 Functional description 3

7.1 Supply voltage 3

7.2 Start-up state 3

7.3 Sweep mode 3

7.4 Reset 3

7.5 Oscillation 3

7.6 Glow time control 5

7.7 Non-overlap time 5

8 Limiting values 6

9 Thermal characteristics 7

10 Characteristics 7

11 Application information 8

12 Package outline 9

13 Revision history 10

14 Legal information 11

14.1 Data sheet status 11

14.2 Definitions 11

14.3 Disclaimers 11

14.4 Trademarks 11

15 Contact information 11

16 Contents 12

Please be aware that important notices concerning this document and the product(s) described herein, have been included in section 'Legal information'.



© NXP B.V. 2008. **All rights reserved.**
 For more information, please visit: <http://www.nxp.com>
 For sales office addresses, please send an email to: salesaddresses@nxp.com
 Date of release: 16 October 2008
 Document identifier: UBA2024_3