

Non-isolated AC / DC converter with fixed 5V output based on high voltage synchronous rectifier architecture

General Description

AP8506 is based on high-voltage synchronous rectifier architecture, integrated with PFM controller and 650V high-reliability MOSFET, specifically designed for small power non-isolated switching power supply. AP8506 has internal high voltage start-up and self-supply circuit, and complete intelligent protections including Over Current Protection (OCP), Under Voltage Lockout (UVLO) and Over Temperature Protection (OTP). Excellent EMI performance could be achieved with Pulse Frequency Modulation.

Features

- Internal 650V avalanche-rugged smart power MOSFET
- Internal HV Start-up Circuit
- Advanced HV synchronous rectifier architecture
- Only Supporting Buck, Buck-Boost topologies
- The output voltage is fixed to 5V
- Semi enclosed steady output current 250mA @230VAC
- Frequency modulation for low EMI
- Excellent constant voltage regulation and High efficiency
- Excellent Protection Coverage:
 - ✧ Over Current Protection (OCP)
 - ✧ Under Voltage Lockout (UVLO)
 - ✧ Over Temperature Protection (OTP)

Applications

- non-isolated assistant power supply
- Household appliance
- Smart Home

Package/Order Information

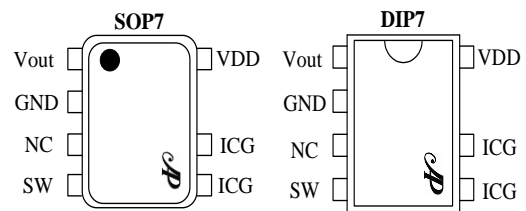

Order Code	Package
AP8506SSC-R1	SOP7
AP8506NSC-T1	DIP7

Typical Circuit

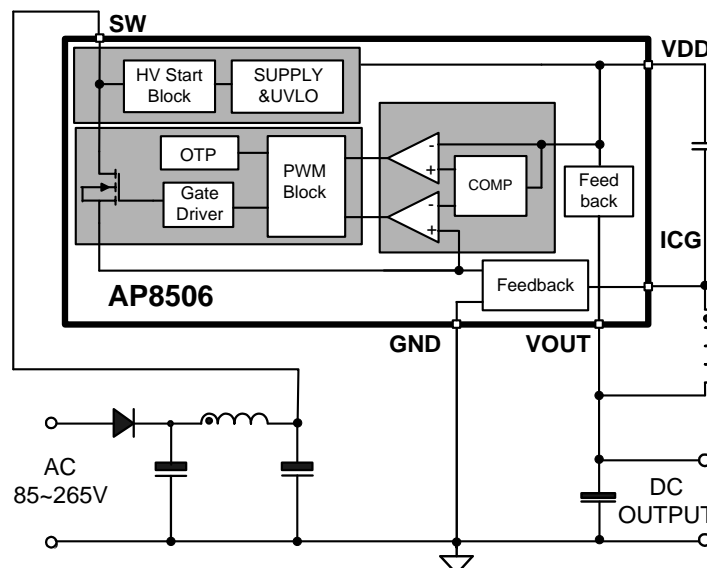

Pin Definitions

Pin Name	Pin Number	Pin Function Description
V _{OUT}	1	System output
GND	2	System ground
NC	3	No connection
SW	4	Drain of the internal MOSFET
ICG	5,6	Ground of AP8506
VDD	7	VDD supply of AP8506

Typical Power

Part number	Input Voltage	Steady output power ⁽¹⁾	Peak Power ⁽²⁾
AP8506	85-265V _{AC}	1.25W(5V250mA)	1.5W(5V300mA)

Note:

1. Maximum output power in a semi enclosed design measured at 75 °C ambient temperature, Duration:2 hours
2. Peak power in a semi enclosed design measured at 75 °C ambient temperature, Duration:1 min

Block Diagram

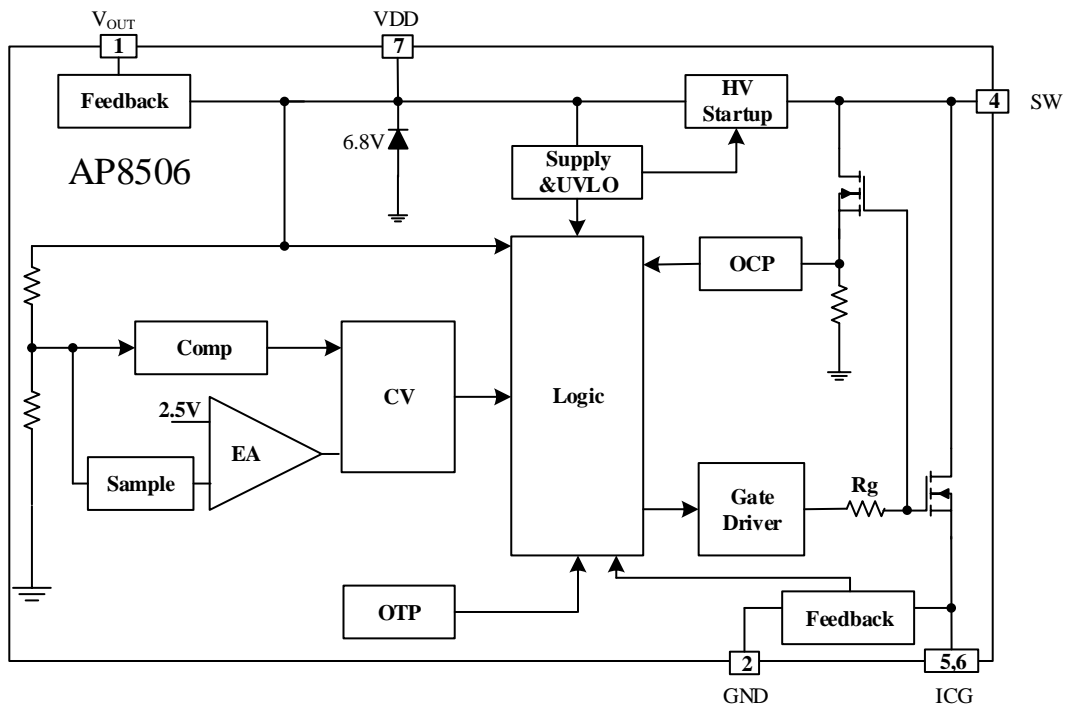

Absolute Maximum Ratings

Supply voltage Pin VDD.....-0.3~10V
 SW, GND, V_{OUT} Pin..... -0.3~600V
 Operating Junction Temperature.....-40~150℃
 Storage Temperature Range.....-55~150℃
 Lead Temperature (Soldering, 10Secs).....260℃
 Note: 1. Test standard: JEDEC JS-001-2014.

Package Thermal Resistance θ_{JC} (SOP7).....40℃/W
 Package Thermal Resistance θ_{JC} (DIP7).....20℃/W
 HBM ESD Protection ⁽¹⁾±4kV
 Pulse Drain Current (T_{pulse}=100us)1.5A

Electrical Characteristics

(T_A = 25 ℃, VDD = 5 V, unless otherwise specified)

PARAMETER	SYMBOL	CONDITIONS	MIN.	TYP.	MAX.	UNIT
Power Section						
Drain Break-down voltage	BV _{DSS}	I _{sw} =250uA, T _J =25 ℃	650	730		V
Off-state drain current	I _{OFF}	V _{sw} =500V, T _J =25 ℃	1	5	10	μA
Drain-source on state resistance	R _{DS(on)}	I _{sw} = 300mA, T _J =25 ℃		10		Ω
Supply Voltage Section						
VDD startup threshold	VDD _{on}		4.5	4.9	5.5	V
VDD under voltage shutdown threshold	VDD _{off}		3.8	4.0	4.5	V
VDD voltage Hysteresis	VDD _{hys}			1		V
VDD clamp voltage	VDD _{clamp}		6.1	6.5	7.5	V
V _{OUT} feedback reference	V _{OUTPUT}		4.9	5.0	5.2	V
Supply Current Section						
VDD charge current	I _{DDch}	VDD=4V		-2		mA
Off-state current	I _{DD0}	VDD=4V		400		uA
Operating supply current,	I _{DD1}	f _s =40KHz		1.0	2.0	mA
Current Sense Section						
Drain current limit	I _{limit}		410	450	490	mA
Leading edge blanking time	T _{LEB}			300		ns
Feedback Input Section						
Minimum turn OFF time	T _{offmin}		18	20	25	μs
Minimum turn ON time	T _{onmax}		6	11	14	μs
Thermal Shutdown Section						
OTP threshold	T _{SD}		135	150		℃
OTP Protect Hysteresis	T _{HYST}			35		℃

Typical Characteristics Plot

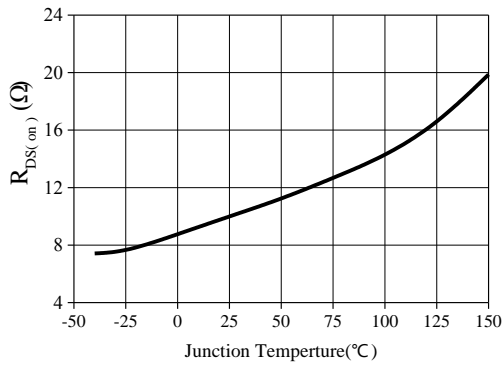

(a) $R_{DS(on)}$ vs T_j

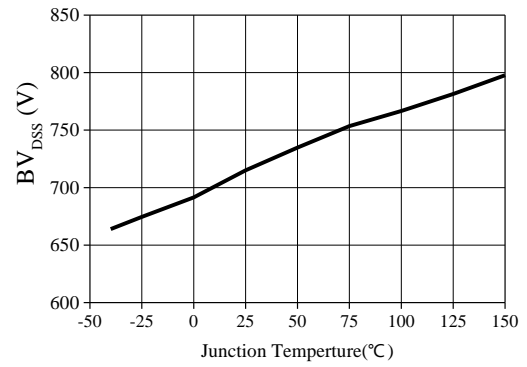

(b) BV_{DSS} vs T_j

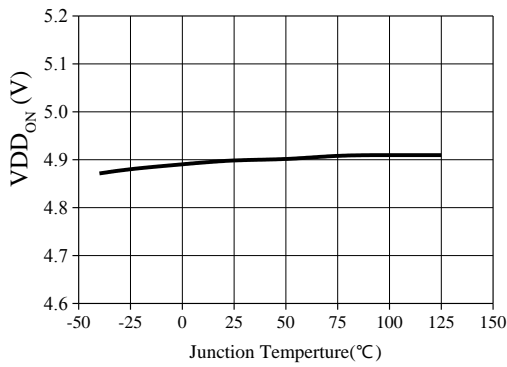

(c) $V_{DD_{on}}$ vs T_j

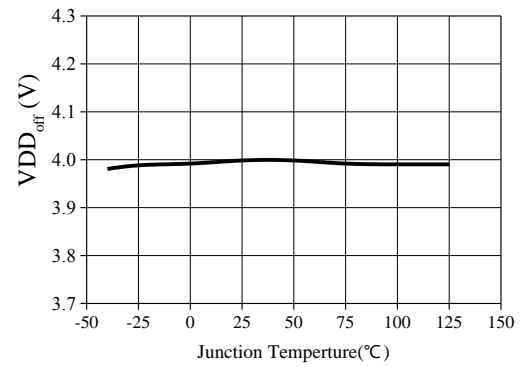

(d) $V_{DD_{off}}$ vs T_j

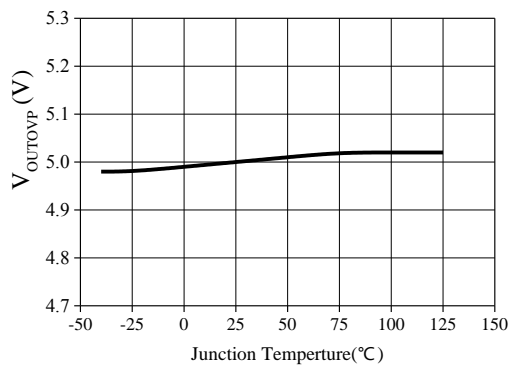

(e) V_{OUTPUT} vs T_j

Functional Description

The AP8506 consists of an integrated Pulse width Modulator (PWM) controller and 650V high reliability MOSFET, specifically designed for small power non-isolated switching power supply, the output voltage is 5V. The AP8506 integrates high voltage startup and self-supply module, which can achieve quick start and ultra-low standby power loss. The AP8506 offers fully intelligent protections including Over Current protection (OCP), Under Voltage Lockout (UVLO) and Over Temperature Protection (OTP). Excellent EMI performance is achieved with Pulse Frequency Modulation.

1. Startup

At start up, the internal high-voltage current source supplies 2mA current to charges the external VDD capacitor. When VDD rises to $V_{DD_{on}}$, AP8506 starts switching and the internal high-voltage current source stops charging the capacitor. When VDD drops to $V_{DD_{off}}$, AP8506 continues switching while the internal high-voltage current source returns to supplies 2mA current to charge the external VDD capacitor. The internal high-voltage regulator self-supplies the IC, so extra component is not needed for power supply.

2. CV Operation Mode

In CV operation, AP8506 samples the feedback signal through VDD pin. While the feedback voltage remains below V_{REF} , the IC turns on the integrated MOSFET. When the current of the inductor reaches the peak current limit (I_{peak}), the integrated MOSFET is turned off. Fig.1-1 and Fig.1-2 shows the operating waveform of key nodes in continuous conduction mode (CCM) and discontinuous conduction mode (DCM). Meanwhile, the IC integrates load compensation function to improve load regulation and CV accuracy.

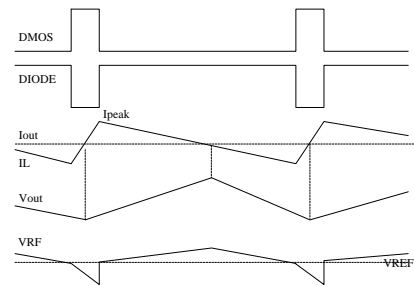

Fig.1-1 Waveform if CCM mode

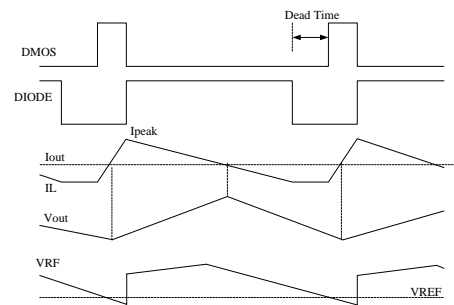

Fig.1-2 Waveform of DCM mode

3. Soft-Start up

In order to regulate peak current in deep CCM mode, AP8506 build in soft-start function, at the first 8ms of start up, the switching frequency decrease to 33% of the maximum frequency, while 8ms to 12ms of startup, the switching frequency decrease to 66% of the maximum frequency. Meanwhile, the leading edge blanking (LEB) is 300ns (Typ.), in order to regulate peak current.

4. Intelligent up and down frequency function

The chip works in PFM mode, i.e. fixed IPEAK adapts to load change by adjusting switch frequency. In order to avoid the audio noise generated by the chip during light load, when the switch frequency is detected to be lower than 18KHz in the chip, the IPEAK can be reduced by 25% immediately to improve the switch frequency, and the IPEAK can be reduced by up to four times; on the other hand, to avoid the chip working in the depth CCM, when the chip working frequency is detected to be higher than 40KHz in the chip, the IPEAK will be restored to the limit immediately.

5. Smart Protection Control

AP8506 has several smart protection functions, such as Over Current protection (OCP), Under Voltage Lockout (UVLO) and Over Temperature Protection (OTP). And all these protections have self-recovery mode.

OCP---If the peak current exceeds I_{limit} , the IC shutdown the power MOSFET immediately and keep on at least T_{offmin} until feedback voltage is lower than V_{REF} .

UVLO---If VDD pin voltage drops below V_{DDoff} , the internal high-voltage current source returns to supply 2mA current to charge the external VDD capacitor until VDD rises to V_{DDon} . Otherwise, self-restart time can be changed by VDD capacitor. The larger the capacitor, the longer the self-restart time is.

OTP---If the inner junction temperature exceeds $150^{\circ}C$, the IC will shut down switching, until the junction temperature falls to $115^{\circ}C$.

Typical Application

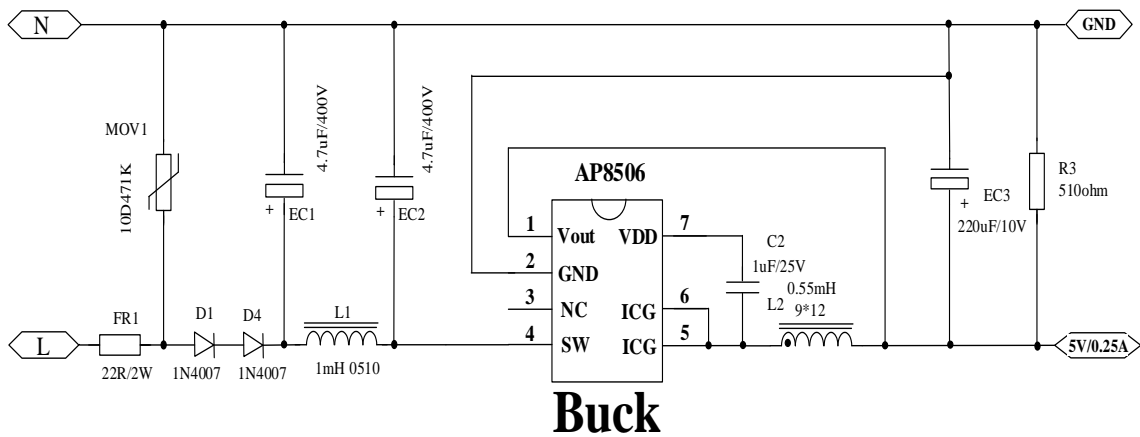
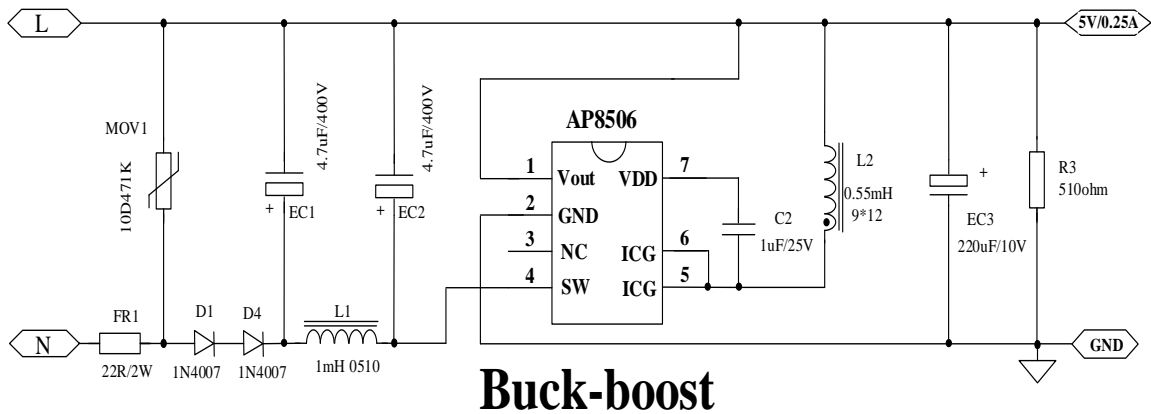

Component Parameter and Layout Considerations:

1. VDD capacitor C2 should be placed at the nearest place from the IC.

Package Information

DIP7 Package Information

Size Symbol	Min. (mm)	Typ. (mm)	Max. (mm)	Size Symbol	Min. (mm)	Typ. (mm)	Max. (mm)
A	3.60	3.80	4.00	c 1	0.24	0.25	0.26
A1	0.51	—	—	D	9.15	9.25	9.35
A2	3.20	3.30	3.40	E1	6.25	6.35	6.45
A3	1.55	1.60	1.65	e	2.54BSC		
b	0.44	—	0.52	eA	7.62REF		
b1	0.43	0.46	0.49	eB	7.62	—	9.30
B1	1.52REF			eC	0	—	0.84
c	0.25	—	0.29	L	3.00	—	—

Top mark	Package
AP8506 YWWXXXXX	DIP7

Note: Y: Year Code; WW: Week Code; XXXXX: Internal Code

Notes:

1. This drawing is subjected to change without notice.
2. Body dimensions do not include mold flash or protrusion.

SOP7 Package Information

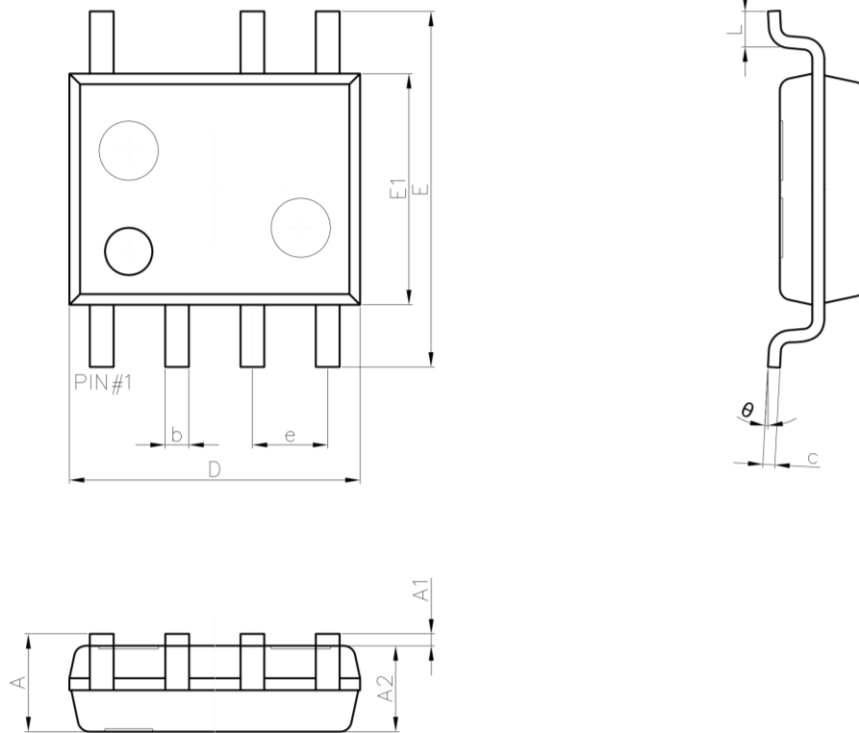

Size symbol	Min. (mm)	Max. (mm)	Size symbol	Min. (mm)	Max. (mm)
A	1.350	1.750	E	5.800	6.200
A1	0.100	0.250	E1	3.800	4.000
A2	1.350	1.550	e	1.27(BSC)	
b	0.330	0.510	L	0.400	0.800
c	0.170	0.250	θ	0°	8°
D	4.700	5.100			

Top mark	Package
AP8506 YWWXXXXX	SOP7

Note: Y: Year Code; WW: Week Code; XXXXX: Internal Code

Notes:

1. This drawing is subjected to change without notice.
2. Body dimensions do not include mold flash or protrusion.

Tape and Reel Information

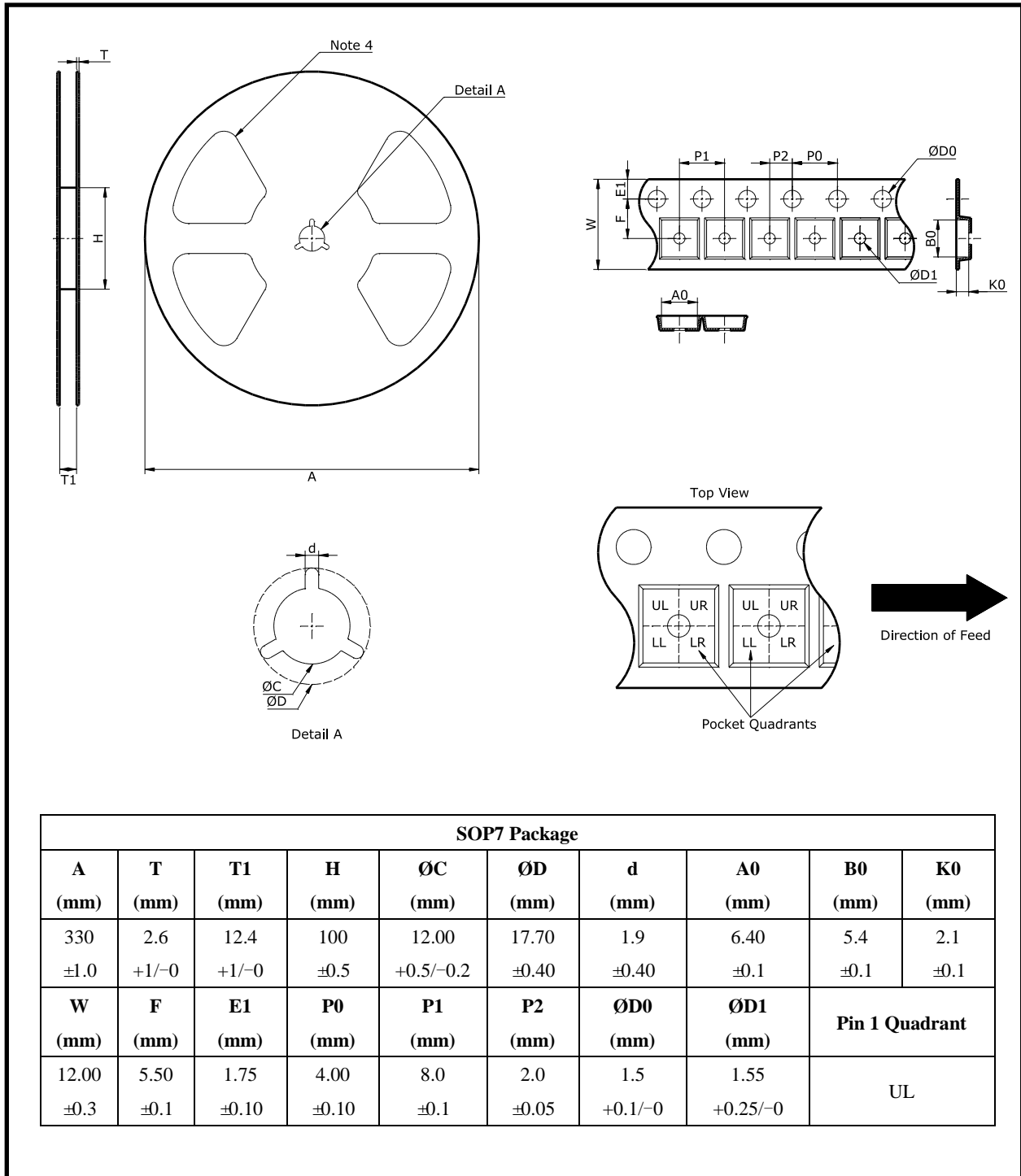

Notes:

1. This drawing is subjected to change without notice.
2. All dimensions are nominal and in mm.
3. This drawing is not in scale and for reference only. Customer can contact Chipown sales representative for further details.
4. The number of flange openings depends on the reel size and assembly site. This drawing shows an example only.

Important Notice

Wuxi Chipown Microelectronics Co. Ltd. reserves the right to make changes without further notice to any products or specifications herein. Wuxi Chipown Microelectronics Co. Ltd. does not assume any responsibility for use of any its products for any particular purpose, nor does Wuxi Chipown Microelectronics Co. Ltd assume any liability arising out of the application or use of any its products or circuits. Wuxi Chipown Microelectronics Co. Ltd does not convey any license under its patent rights or other rights nor the rights of others.