

## Serial real-time clock

### Features summary

- Counters for seconds, minutes, hours, day, month, years, and century
- 32kHz crystal oscillator integrating load capacitance (12.5pF) providing exceptional oscillator stability and high crystal series resistance operation
- Serial interface supports I<sup>2</sup>C bus (100kHz protocol)
- Ultra low battery supply current of 0.8μA (typ@3V)
- 2.0 to 5.5V clock operating voltage
- Automatic switch-over and deselect circuitry (for 3V application select M41T00S datasheet)
- Software clock calibration to compensate crystal deviation due to temperature
- Automatic leap year compensation
- Operating temperature of -40 to 85°C

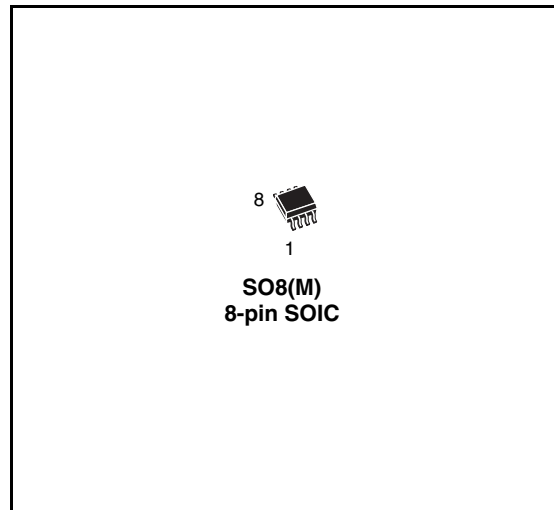

# Contents

<b>1</b>	<b>Summary description</b> .....	<b>3</b>
<b>2</b>	<b>Pin settings</b> .....	<b>4</b>
	2.1 Pin connection .....	4
	2.2 Pin description .....	4
<b>3</b>	<b>Block diagram</b> .....	<b>5</b>
<b>4</b>	<b>Operation</b> .....	<b>6</b>
	4.1 Wire bus characteristics .....	6
	4.2 Bus not busy .....	6
	4.3 Start data transfer .....	6
	4.4 Stop data transfer .....	7
	4.5 Data valid .....	7
	4.6 Acknowledge .....	7
	4.7 Characteristics .....	9
	4.8 Read mode .....	9
	4.9 Write mode .....	11
	4.10 Data retention mode .....	11
<b>5</b>	<b>M41T00 clock operation</b> .....	<b>13</b>
	5.1 Clock calibration .....	14
	5.2 Output driver pin .....	15
	5.3 Initial power-on defaults .....	16
<b>6</b>	<b>Maximum ratings</b> .....	<b>17</b>
<b>7</b>	<b>DC and AC parameters</b> .....	<b>18</b>
<b>8</b>	<b>Package mechanical data</b> .....	<b>20</b>

9	Order codes .....	22
10	Revision history .....	23

# 1 Summary description

The M41T00 is a low power serial real time clock with a built-in 32.768kHz oscillator (external crystal controlled). Eight bytes of the RAM are used for the clock/calendar function and are configured in binary coded decimal (BCD) format. Addresses and data are transferred serially via a two-line bi-directional bus. The built-in address register is incremented automatically after each WRITE or READ data byte.

The M41T00 clock has a built-in power sense circuit which detects power failures and automatically switches to the battery supply during power failures. The energy needed to sustain the RAM and clock operations can be supplied from a small lithium coin cell.

Typical data retention time is in excess of 5 years with a 50mA/h 3V lithium cell (see [Section 4.10: Data retention mode](#) for AC/DC Characteristics). The M41T00 is supplied in 8 lead plastic small outline package.

**Figure 1. Logic symbol**

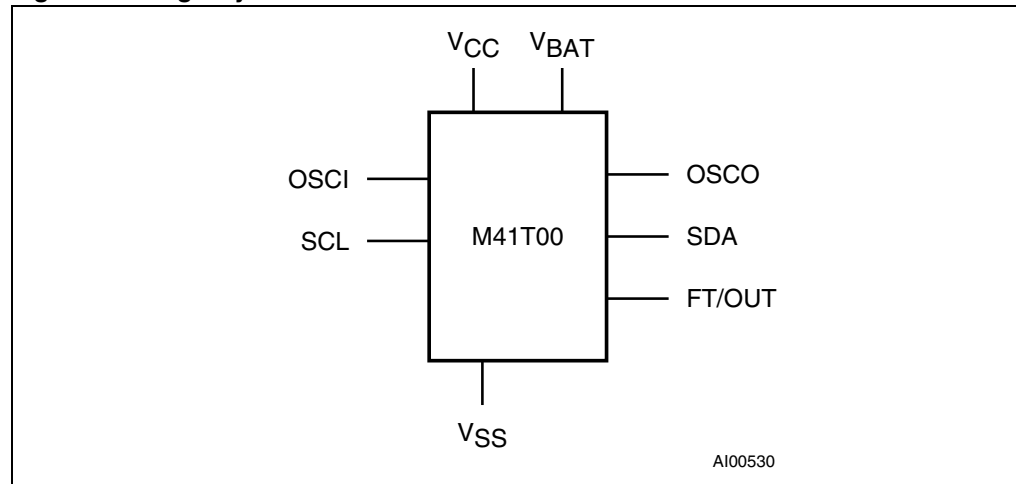

## 2 Pin settings

### 2.1 Pin connection

Figure 2. SOIC connection

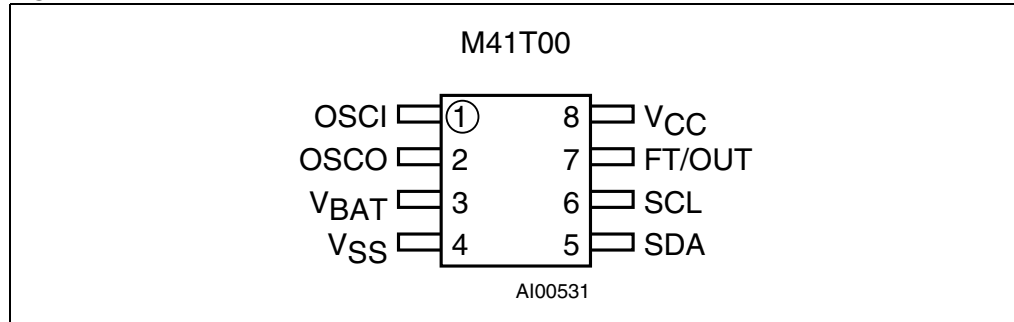

### 2.2 Pin description

Table 1. Pin description

Symbol	Name and function
OSCI	Oscillator input
OSCO	Oscillator output
FT/OUT	Frequency test / output driver (open drain)
SCL	Serial clock
SDA	Serial data address input/output
V <sub>BAT</sub>	Battery supply voltage
AIN	Audio input
V <sub>SS</sub>	Ground
V <sub>CC</sub>	Supply voltage

### 3 Block diagram

Figure 3. Block diagram

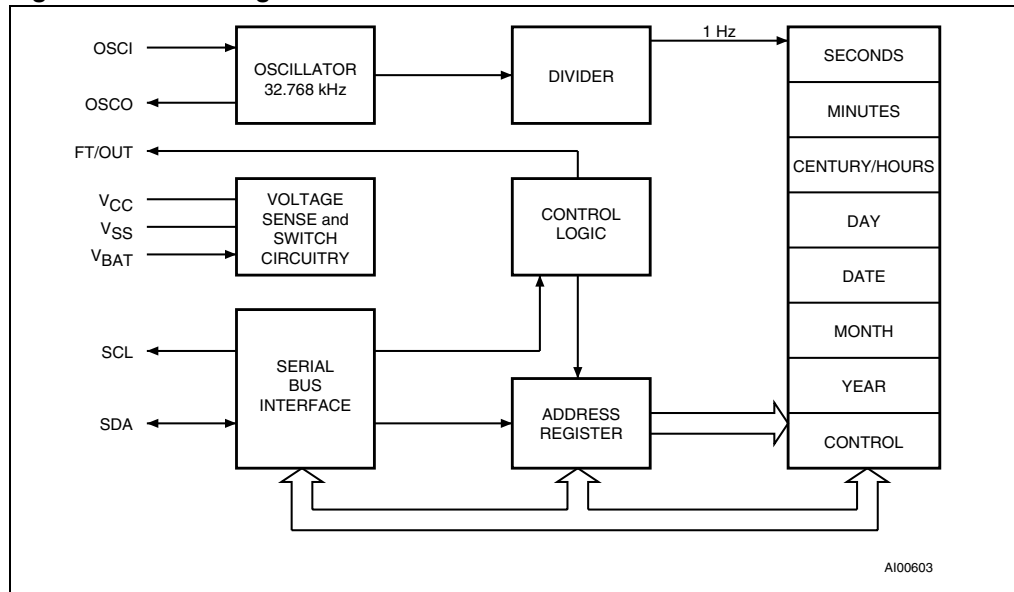

## 4 Operation

The M41T00 clock operates as a slave device on the serial bus. Access is obtained by implementing a start condition followed by the correct slave address (D0h). The 8 bytes contained in the device can then be accessed sequentially in the following order:

1. Seconds register
2. Minutes register
3. Century/hours register
4. Day register
5. Date register
6. Month register
7. Years register
8. Control register

The M41T00 clock continually monitors  $V_{CC}$  for an out of tolerance condition. Should  $V_{CC}$  fall below  $V_{SO}$ , the device terminates an access in progress and resets the device address counter. Inputs to the device will not be recognized at this time to prevent erroneous data from being written to the device from an out of tolerance system. When  $V_{CC}$  falls below  $V_{SO}$ , the device automatically switches over to the battery and powers down into an ultra low current mode of operation to conserve battery life. Upon power-up, the device switches from battery to  $V_{CC}$  at  $V_{SO}$  and recognizes inputs.

### 4.1 Wire bus characteristics

This bus is intended for communication between different ICs. It consists of two lines: one bi-directional for data signals (SDA) and one for clock signals (SCL). Both the SDA and the SCL lines must be connected to a positive supply voltage via a pull-up resistor.

The following protocol has been defined:

- Data transfer may be initiated only when the bus is not busy.
- During data transfer, the data line must remain stable whenever the clock line is High. Changes in the data line while the clock line is High will be interpreted as control signals.

Accordingly, the following bus conditions have been defined:

## 4.2 Bus not busy

Both data and clock lines remain high.

## 4.3 Start data transfer

A change in the state of the data line, from high to low, while the clock is high, defines the START condition.

## 4.4 Stop data transfer

A change in the state of the data line, from low to high, while the clock is high, defines the STOP condition.

## 4.5 Data valid

The state of the data line represents valid data when after a start condition, the data line is stable for the duration of the High period of the clock signal. The data on the line may be changed during the Low period of the clock signal. There is one clock pulse per bit of data.

Each data transfer is initiated with a start condition and terminated with a stop condition. The number of data bytes transferred between the start and stop conditions is not limited. The information is transmitted byte-wide and each receiver acknowledges with a ninth bit.

By definition, a device that gives out a message is called “transmitter”, the receiving device that gets the message is called “receiver”. The device that controls the message is called “master”. The devices that are controlled by the master are called “slaves”.

## 4.6 Acknowledge

Each byte of eight bits is followed by one acknowledge bit. This acknowledge bit is a low level put on the bus by the receiver, whereas the master generates an extra acknowledge related clock pulse.

A slave receiver which is addressed is obliged to generate an acknowledge after the reception of each byte. Also, a master receiver must generate an acknowledge after the reception of each byte that has been clocked out of the slave transmitter.

The device that acknowledges has to pull down the SDA line during the acknowledge clock pulse in such a way that the SDA line is a stable low during the high period of the acknowledge related clock pulse. Of course, setup and hold times must be taken into account. A master receiver must signal an end-of-data to the slave transmitter by not generating an acknowledge on the last byte that has been clocked out of the slave. In this

case, the transmitter must leave the data line High to enable the master to generate the STOP condition.

**Figure 4. Serial bus data transfer sequence**

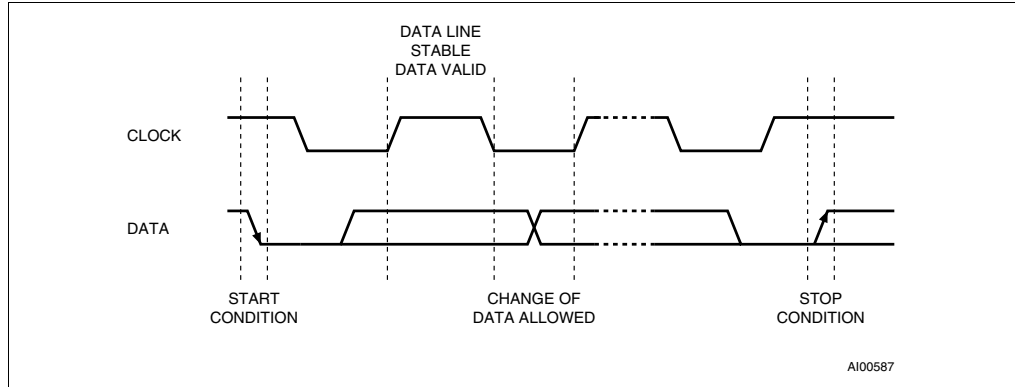

**Figure 5. Acknowledgement sequence**

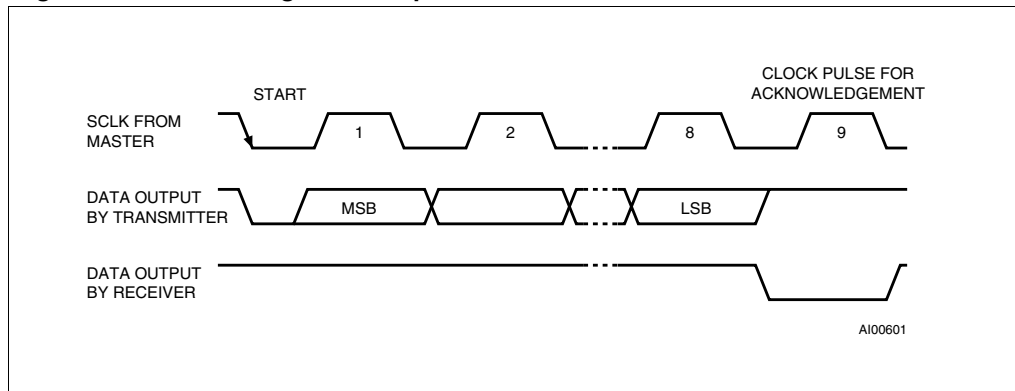

**Figure 6. Bus timing requirements sequence**

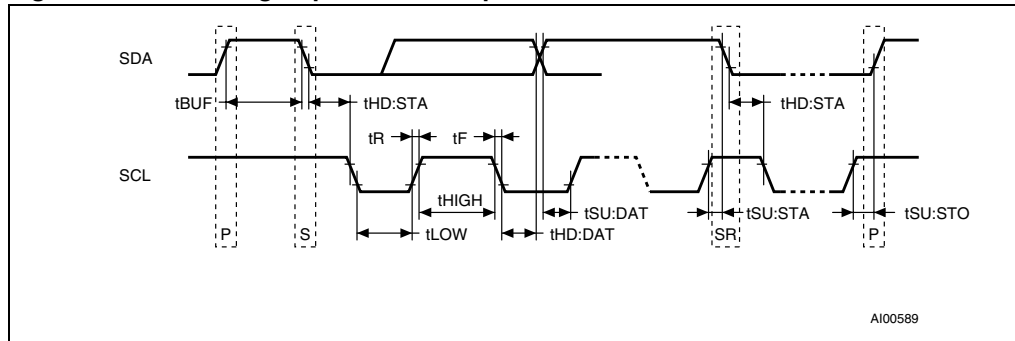

Note: P = STOP and S = START

## 4.7 Characteristics

Table 2. AC characteristics

Symbol	Parameter <sup>(1)</sup>	Min	Typ	Max	Units
f <sub>SCL</sub>	SCL clock frequency	0		100	kHz
t <sub>LOW</sub>	Clock low period	4.7			μs
t <sub>HIGH</sub>	Clock high period	4			μs
t <sub>R</sub>	SDA and SCL rise time			1	μs
t <sub>F</sub>	SDA and SCL fall time			300	ns
t <sub>HD:STA</sub>	START condition hold time (after this period the first clock pulse is generated)	4			μs
t <sub>SU:STA</sub>	START condition setup time (only relevant for a repeated start condition)	4.7			μs
t <sub>HD:DAT</sub> <sup>(2)</sup>	Data hold time	0			ns
t <sub>SU:DAT</sub>	Data setup time	250			ns
t <sub>SU:STO</sub>	STOP condition setup time	4.7			μs
t <sub>BUF</sub>	Time the bus must be free before a new transmission can start	4.7			μs

1. Valid for ambient operating temperature: T<sub>A</sub> = -40 to 85°C; V<sub>CC</sub> = 2.0 to 5.5V (except where noted).
2. Transmitter must internally provide a hold time to bridge the undefined region (300ns max) of the falling edge of SCL.

## 4.8 Read mode

In this mode, the master reads the M41T00 slave after setting the slave address (see [Figure 7](#)). Following the WRITE Mode Control Bit (R/W = 0) and the acknowledge bit, the word address An is written to the on-chip address pointer. Next the START condition and slave address are repeated, followed by the read mode control bit (R/W = 1). At this point, the master transmitter becomes the master receiver. The data byte which was addressed will be transmitted and the master receiver will send an acknowledge bit to the slave transmitter. The address pointer is only incremented on reception of an acknowledge bit. The M41T00 slave transmitter will now place the data byte at address An+1 on the bus. The master receiver reads and acknowledges the new byte and the address pointer is incremented to An+2.

This cycle of reading consecutive addresses will continue until the master receiver sends a STOP condition to the slave transmitter.

An alternate READ Mode may also be implemented, whereby the master reads the M41T00 slave without first writing to the (volatile) address pointer. The first address that is read is the last one stored in the pointer.

**Figure 7. Slave address location**

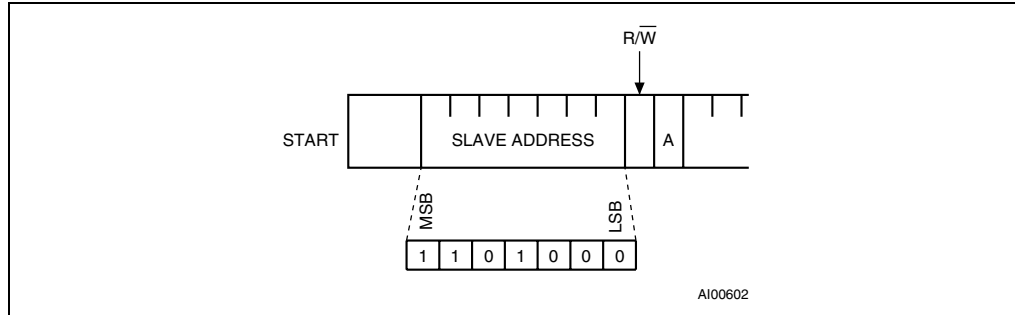

**Figure 8. READ mode sequence**

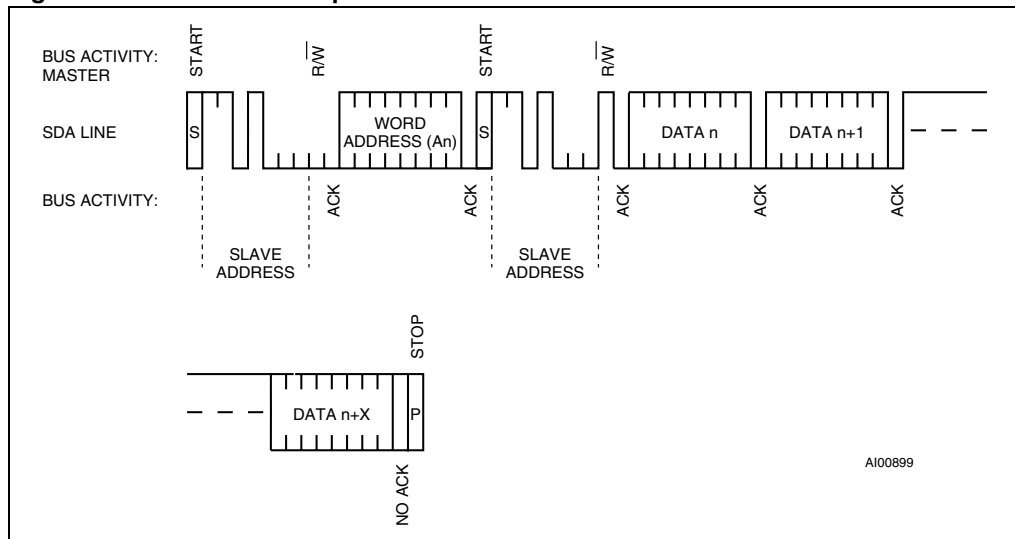

**Figure 9. Alternate READ mode sequence**

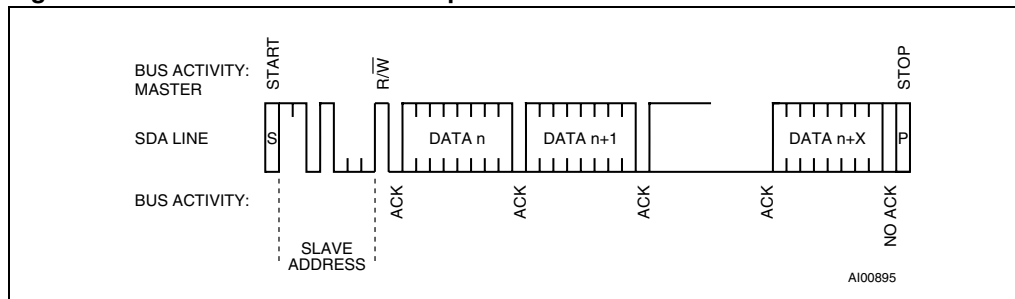

### 4.9 Write mode

In this mode the master transmitter transmits to the M41T00 slave receiver. Bus protocol is shown in [Figure 10](#). Following the START condition and slave address, a logic '0' (R/W = 0) is placed on the bus and indicates to the addressed device that word address  $A_n$  will follow and is to be written to the on-chip address pointer. The data word to be written to the memory is strobed in next and the internal address pointer is incremented to the next memory location within the RAM on the reception of an acknowledge clock. The M41T00 slave receiver will send an acknowledge clock to the master transmitter after it has received the slave address and again after it has received the word address and each data byte (see [Figure 7](#)).

**Figure 10. WRITE mode sequence**

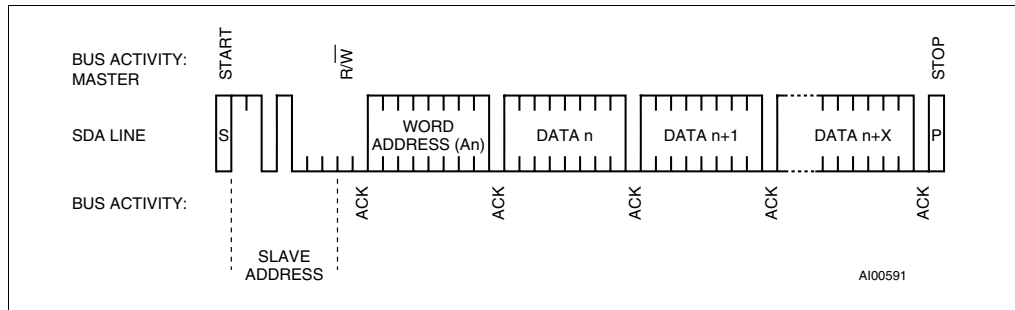

### 4.10 Data retention mode

With valid  $V_{CC}$  applied, the M41T00 can be accessed as described above with READ or WRITE cycles. Should the supply voltage decay, the M41T00 will automatically deselect, write protecting itself when  $V_{CC}$  falls (see [Figure 11](#)).

**Figure 11. Power down/up mode ac waveforms**

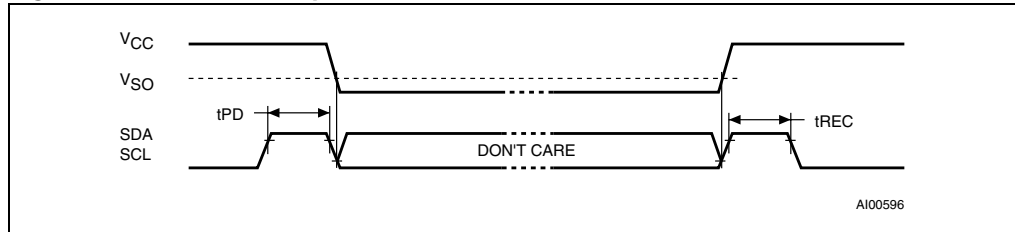

**Table 3. RTC power down/up AC characteristics**

Symbol	Parameter <sup>(1)</sup> <sup>(2)</sup>	Min	Typ	Max	Unit
$t_{PD}$	SCL and SDA at VIH before power down	0			ns
$t_{rec}$	SCL and SDA at VIH after power up	10			$\mu$ s

- Valid for ambient operating temperature:  $T_A = -40$  to  $85^\circ\text{C}$ ;  $V_{CC} = 2.0$  to  $5.5\text{V}$  (except where otherwise noted).
- $V_{CC}$  fall time should not exceed  $5\text{mV}/\mu\text{s}$ .

**Table 4. RTC power down/up trip points DC characteristics**

Symbol	Parameter <sup>(1)</sup> <sup>(2)</sup>	Min	Typ	Max <sup>(3)</sup>	Unit
$V_{SO}^{(4)}$	Back-up switchover voltage	$V_{BAT} - 0.80$	$V_{BAT} - 0.50$	$V_{BAT} - 0.30$	V

- Valid for ambient operating temperature:  $T_A = -40$  to  $85^\circ\text{C}$ ;  $V_{CC} = 2.0$  to  $5.5\text{V}$  (except where otherwise noted).
- All voltages referenced to  $V_{SS}$ .
- In  $3.3\text{V}$  application, if initial battery voltage is  $> 3.4\text{V}$ , it may be necessary to reduce battery voltage (i.e., through wave soldering the battery) in order to avoid inadvertent switchover/deselection for  $V_{CC} - 10\%$  operation.
- Switch-over and deselect point.

## 5 M41T00 clock operation

The eight byte clock register (see [Table 5](#)) is used to both set the clock and to read the date and time from the clock, in a binary coded decimal format. Seconds, minutes, and hours are contained within the first three registers. Bits D6 and D7 of clock register 2 (century/hours register) contain the century enable bit (CEB) and the century bit (CB). Setting CEB to a '1' will cause CB to toggle, either from '0' to '1' or from '1' to '0' at the turn of the century (depending upon its initial state). If CEB is set to a '0', CB will not toggle. Bits D0 through D2 of register 3 contain the day (day of week). Registers 4, 5 and 6 contain the date (day of month), month and years. The final register is the control register (this is described in the clock calibration section). Bit D7 of register 0 contains the STOP Bit (ST). Setting this bit to a '1' will cause the oscillator to stop. If the device is expected to spend a significant amount of time on the shelf, the oscillator may be stopped to reduce current drain. When reset to a '0' the oscillator restarts within one second.

*In order to guarantee oscillator start-up after the initial power-up, set the ST Bit to a '1,' then reset this bit to a '0.' This sequence enables a "kick start" circuit which aids the oscillator start-up during worst case conditions of voltage and temperature.*

The seven Clock Registers may be read one byte at a time, or in a sequential block. The control register (address location 7) may be accessed independently. Provision has been made to assure that a clock update does not occur while any of the seven clock addresses are being read. If a clock address is being read, an update of the clock registers will be delayed by 250ms to allow the read to be completed before the update occurs. This will prevent a transition of data during the read.

*Note: This 250ms delay affects only the clock register update and does not alter the actual clock time.*

Table 5. Register map

Address	Data								Function/Range BCD Format	
	D7	D6	D5	D4	D3	D2	D1	D0		
0	ST	10 Seconds			Seconds				Seconds	00-59
1	X	10 Minutes			Minutes				Minutes	00-59
2	CEB <sup>(1)</sup>	CB	10 Hours		Hours				Century/Hours	0-1/00-23
3	X	X	X	X	X	Day			Day	01-07
4	X	X	10 Date		Date				Date	01-31
5	X	X	X	10 M.	Month				Month	01-12
6	10 Years				Years				Year	00-99
7	OUT	FT	S	Calibration					Control	

**Keys:**

S= SIGN Bit  
 FT = FREQUENCY TEST Bit  
 ST = STOP Bit  
 OUT = Output level  
 X = Don't care  
 CEB = Century Enable Bit  
 CB = Century Bit

*Note:* When CEB is set to '1', CB will toggle from '0' to '1' or from '1' to '0' at the turn of the century (dependent upon the initial value set). When CEB is set to '0', CB will not toggle.

**5.1 Clock calibration**

The M41T00 is driven by a quartz controlled oscillator with a nominal frequency of 32,768Hz. The devices are tested not to exceed 35 ppm (parts per million) oscillator frequency error at 25°C, which equates to about ±1.53 minutes per month. With the calibration bits properly set, the accuracy of each M41T00 improves to better than ±2 ppm at 25°C.

The oscillation rate of any crystal changes with temperature (see [Figure 12](#)). Most clock chips compensate for crystal frequency and temperature shift error with cumbersome trim capacitors. The M41T00 design, however, employs periodic counter correction. The calibration circuit adds or subtracts counts from the oscillator divider circuit at the divide by 256 stage, as shown in [Figure 13](#). The number of times pulses are blanked (subtracted, negative calibration) or split (added, positive calibration) depends upon the value loaded into the five-bit calibration byte found in the control register. Adding counts speeds the clock up, subtracting counts slows the clock down.

The calibration byte occupies the five lower order bits (D4-D0) in the control register (addr 7). This byte can be set to represent any value between 0 and 31 in binary form. Bit D5 is a sign bit; '1' indicates positive calibration, '0' indicates negative calibration. Calibration occurs

within a 64minute cycle. The first 62 minutes in the cycle may, once per minute, have one second either shortened by 128 or lengthened by 256 oscillator cycles. If a binary '1' is loaded into the register, only the first 2 minutes in the 64 minute cycle will be modified; if a binary 6 is loaded, the first 12 will be affected, and so on.

Therefore, each calibration step has the effect of adding 512 or subtracting 256 oscillator cycles for every 125,829,120 actual oscillator cycles, that is +4.068 or -2.034 ppm of adjustment per calibration step in the calibration register. Assuming that the oscillator is in fact running at exactly 32,768Hz, each of the 31 increments in the calibration byte would represent +10.7 or -5.35 seconds per month which corresponds to a total range of +5.5 or -2.75 minutes per month.

Two methods are available for ascertaining how much calibration a given M41T00 may require. The first involves simply setting the clock, letting it run for a month and comparing it to a known accurate reference (like WWV broadcasts). While that may seem crude, it allows the designer to give the end user the ability to calibrate his clock as his environment may require, even after the final product is packaged in a non-user serviceable enclosure. All the designer has to do is provide a simple utility that accessed the calibration byte.

The second approach is better suited to a manufacturing environment, and involves the use of some test equipment. When the Frequency Test (FT) Bit, the seventh-most significant bit in the Control Register, is set to a '1', and the oscillator is running at 32,768Hz, the FT/OUT pin of the device will toggle at 512Hz. Any deviation from 512Hz indicates the degree and direction of oscillator frequency shift at the test temperature.

For example, a reading of 512.01024Hz would indicate a +20 ppm oscillator frequency error, requiring a -10(XX001010) to be loaded into the calibration byte for correction. Note that setting or changing the calibration byte does not affect the frequency test output frequency.

**Figure 12. Crystal accuracy across temperature**

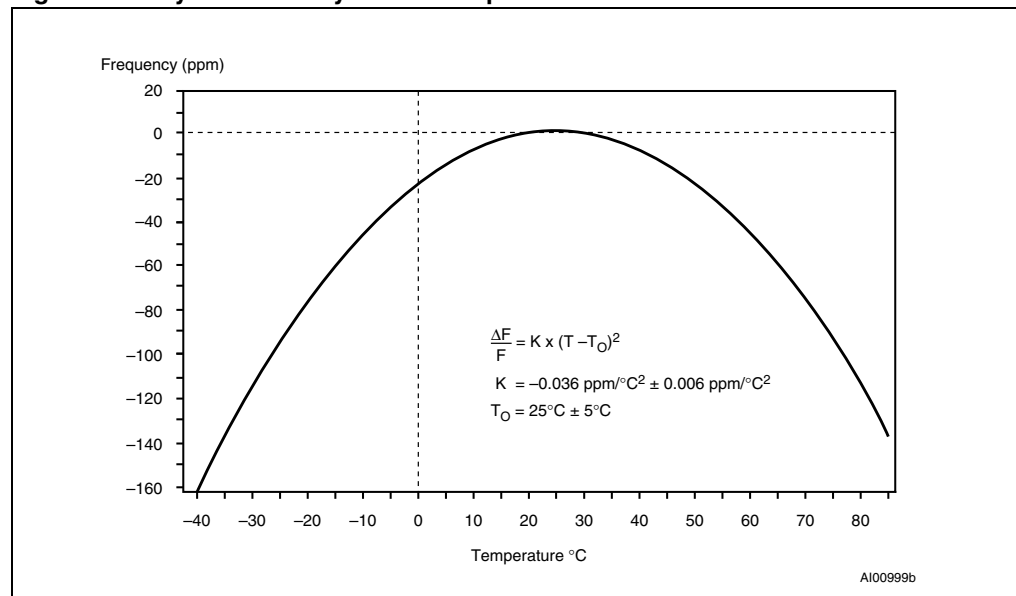

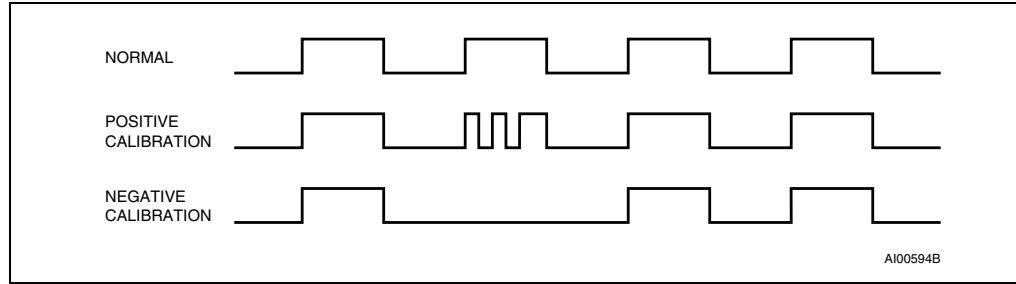
**Figure 13. Clock calibration**

## 5.2 Output driver pin

When the FT Bit is not set, the FT/OUT pin becomes an output driver that reflects the contents of D7 of the control register. In other words, when D6 of address 7 is a zero and D7 of address 7 is a zero and then the FT/OUT pin will be driven low.

*Note: The FT/OUT pin is open drain which requires an external pull-up resistor.*

## 5.3 Initial power-on defaults

Upon initial application of power to the device, the FT Bit will be set to a '0' and the OUT Bit will be set to a '1'. All other Register bits will initially power-on in a random state.

## 6 Maximum ratings

Stressing the device above the rating listed in the "Absolute maximum ratings" table may cause permanent damage to the device. These are stress ratings only and operation of the device at these or any other conditions above those indicated in the operating sections of this specification is not implied.

Exposure to absolute maximum rating conditions for extended periods may affect device reliability. Refer also to the STMicroelectronics SURE Program and other relevant quality documents.

**Table 6. Absolute maximum ratings**

Symbol	Parameter	Value	Unit
$T_{STG}^{(1)}$	Storage temperature ( $V_{CC}$ off, oscillator off)	-55 to 125	°C
$T_A$	Ambient operating temperature	-40 to 85	°C
$V_{IO}$	Input or output voltages	-0.3 to 7	V
$V_{CC}$	Supply voltage	-0.3 to 7	V
$I_O$	Output current	20	mA
$P_D$	Power dissipation	0.25	W

1. For SO package, standard (SnPb) lead finish: reflow at peak temperature of 225°C (total thermal budget not to exceed 180°C for between 90 to 150 seconds).

**Caution:** Negative undershoots below -0.3V are not allowed on any pin while in the back-up mode.

## 7 DC and AC parameters

This section summarizes the operating and measurement conditions, as well as the DC and AC characteristics of the device. The parameters in the following DC and AC Characteristic tables are derived from tests performed under the measurement

Conditions listed in the relevant tables. Designers should check that the operating conditions in their projects match the measurement conditions when using the quoted parameters.

**Table 7. Operating and AC measurement conditions**

Parameter	M41T00
Supply voltage ( $V_{CC}$ )	2.0 to 5.5V
Ambient operating temperature ( $T_A$ )	-40 to 85°C
Load capacitance ( $C_L$ )	100pF
Input rise and fall times	$\leq 5$ ns
Input pulse voltages	$0.2V_{CC}$ to $0.8V_{CC}$
Input and output timing reference voltages	$0.3V_{CC}$ to $0.7V_{CC}$

*Note:* Output Hi-Z is defined as the point where data is no longer driven.

**Figure 14. AC testing input/output waveform**

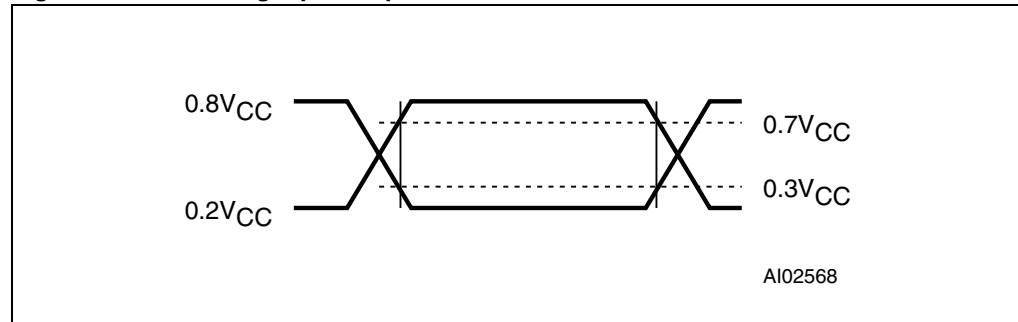

**Table 8. Capacitance**

Symbol	Parameter <sup>(1) (2)</sup>	Min	Max	Unit
$C_{IN}$	Input capacitance (SCL)		7	pF
$C_{OUT}^{(3)}$	Output capacitance (SDA, FT/OUT)		10	pF
$t_{LP}$	Low-pass filter input time constant (SDA and SCL)	250	1000	ns

1. Effective capacitance measured with power supply at 3.3V; sampled only, not 100% tested

2. At 25°C,  $f = 1$ MHz

3. Outputs deselected

Table 9. DC characteristics

Symbol	Parameter	Test condition <sup>(1)</sup>	Min	Typ	Max	Unit
$I_{LI}$	Input leakage current	$0V = V_{IN} = V_{CC}$			$\pm 1$	$\mu A$
$I_{LO}$	Output leakage current	$0V = V_{OUT} = V_{CC}$			$\pm 1$	$\mu A$
$I_{CC1}$	Supply current	Switch frequency = 100kHz			300	$\mu A$
$I_{CC2}$	RTC supply current (standby)	SCL, SDA = $V_{CC} - 0.3V$			70	$\mu A$
$V_{IL}$	Input low voltage		-0.3		$0.3V_{CC}$	V
$V_{IH}$	Input high voltage		$0.7V_{CC}$		$V_{CC} + 0.5$	V
$V_{OL}$	Output low voltage	$I_{OL} = 3.0mA$			0.4	V
	Output Low Voltage (Open Drain)	FT/OUT			5.5	V
$V_{BAT}^{(2)}$	Battery supply voltage		$2.5^{(3)}$		$3.5^{(4)}$	V
$I_{BAT}$	Battery supply current	$T_A = 25^\circ C$ , $V_{CC} = 0V$ oscillator ON, $V_{BAT} = 3V$		0.8	1	$\mu A$

- Valid for ambient operating temperature:  $T_A = -40$  to  $85^\circ C$ ;  $V_{CC} = 2.0$  to  $5.5V$  (except where otherwise noted).
- STMicroelectronics recommends the RAYOVAC BR1225 or BR1632 (or equivalent) as the battery supply.
- After switchover ( $V_{SO}$ ),  $V_{BAT(min)}$  can be  $2.0V$  for crystal with  $R_S = 40K\Omega$ .
- For rechargeable back-up,  $V_{BAT(max)}$  may be considered  $V_{CC}$ .

Table 10. Crystal electrical characteristics

Symbol	Parameter <sup>(1) (2)</sup>	Min	Typ	Max	Units
$f_O$	Resonant frequency		32.768		kHz
$R_S$	Series resistance			60	$K\Omega$
$C_L$	Load capacitance		12.5		pF

- Externally supplied if using the SO8 package. STMicroelectronics recommends the KDS DT-38: 1TA/1TC252E127, Tuning Fork Type (thru-hole) or the DMX-26S: 1TJS125FH2A212, (SMD) quartz crystal for industrial temperature operations. KDS can be contacted at kouhou@kdsj.co.jp or http://www.kdsj.co.jp for further information on this crystal type.
- Load capacitors are integrated within the M41T00. Circuit board layout considerations for the 32.768kHz crystal of minimum trace lengths and isolation from RF generating signals should be taken into account.

## 8 Package mechanical data

In order to meet environmental requirements, ST offers these devices in ECOPACK® packages. These packages have a Lead-free second level interconnect . The category of second level interconnect is marked on the package and on the inner box label, in compliance with JEDEC Standard JESD97. The maximum ratings related to soldering conditions are also marked on the inner box label. ECOPACK is an ST trademark. ECOPACK specifications are available at: [www.st.com](http://www.st.com)

Figure 15. SO8 – 8-lead plastic small outline package mechanical data

Symb	mm			inches		
	Typ	Min	Max	Typ	Min	Max
A		1.35	1.75		0.053	0.069
A1		0.10	0.25		0.004	0.010
B		0.33	0.51		0.013	0.020
C		0.19	0.25		0.007	0.010
D		4.80	5.00		0.189	0.197
E		3.80	4.00		0.150	0.157
e	1.27	–	–	0.050	–	–
H		5.80	6.20		0.228	0.244
h		0.25	0.50		0.010	0.020
L		0.40	0.90		0.016	0.035
a		0°	8°		0°	8°
N	8			8		
CP			0.10			0.004

Figure 16. DFN16 (5mm x 4mm) package outline

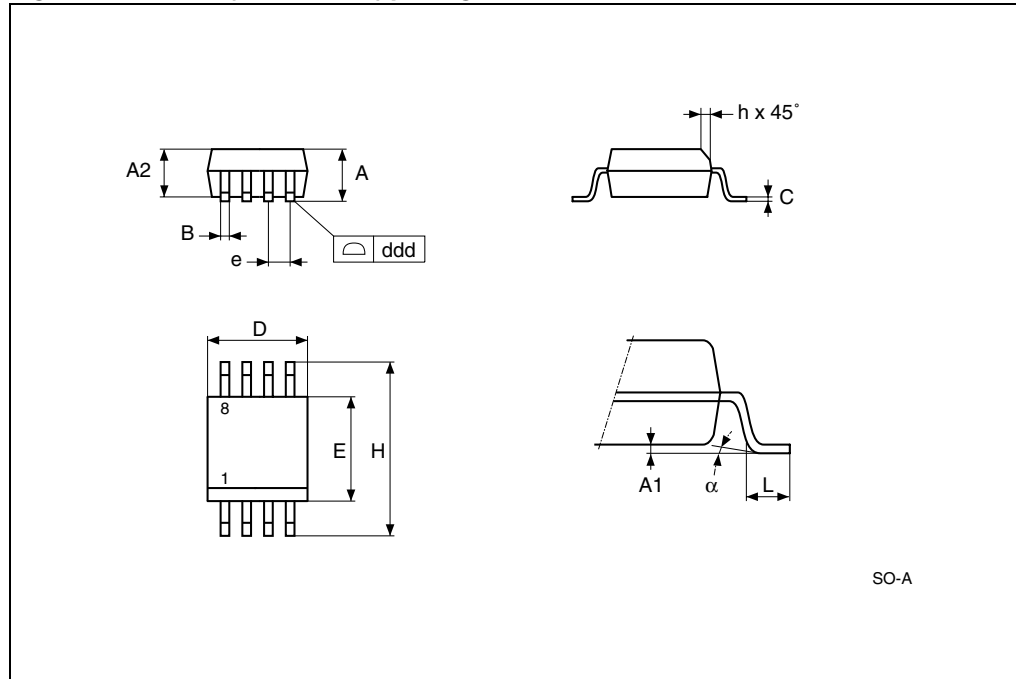

Note: Drawing is not to scale.

## 9 Order codes

**Figure 17. Ordering Information scheme**

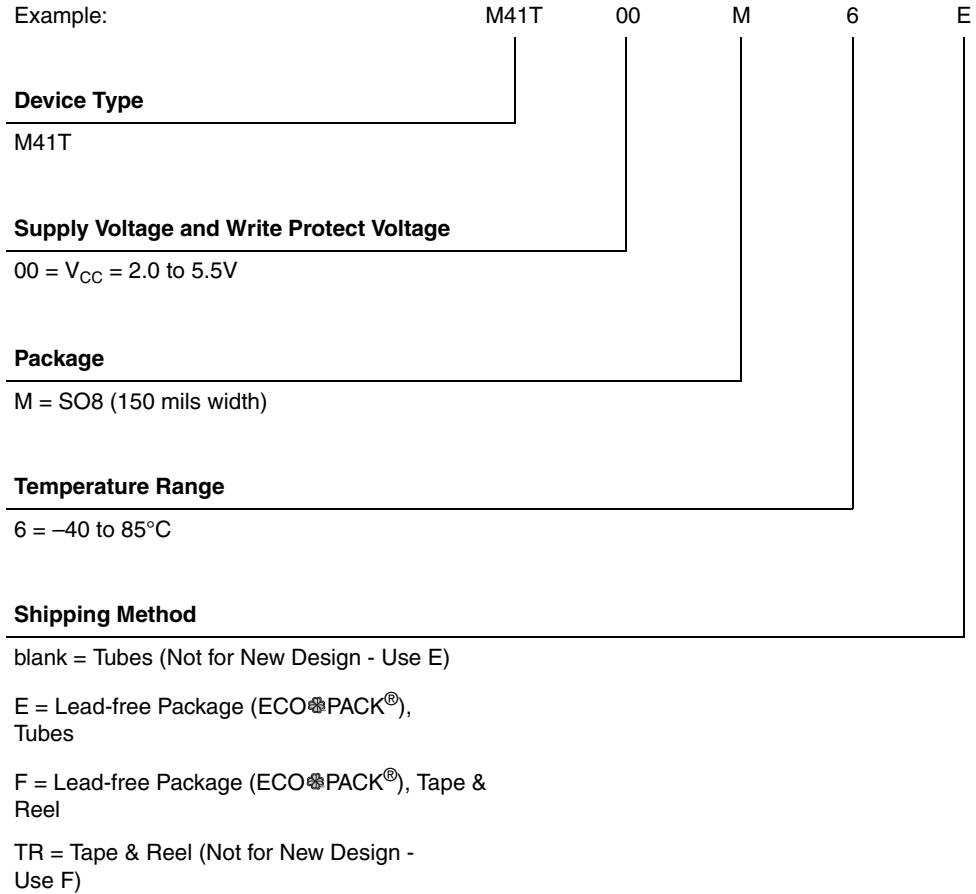

## 10 Revision history

**Table 11. Revision history**

Date	Revision	Changes
March 1999	1.0	First Issue
05/15/00	1.1	AC Characteristic conditions changed ( <a href="#">Table 2</a> )
07/25/00	1.2	Crystal Electrical Characteristics: R <sub>S</sub> Max changed ( <a href="#">Table 10</a> )
12/12/00	1.3	Edit V <sub>SO</sub> ( <a href="#">Table 3</a> )
01/24/01	2.0	Reformatted
02/27/01	3.0	Document Status changed
07/17/01	3.1	Change to DC and AC Characteristics ( <a href="#">Table 9</a> , <a href="#">Table 2</a> ); added temp./voltage info. to tables
11/27/01	3.2	Features, (page 1); DC Characteristics ( <a href="#">Table 9</a> ); Crystal Electrical ( <a href="#">Table 10</a> ); Power Down/Up Trip Points ( <a href="#">Table 3</a> ) changes; add table footnote ( <a href="#">Table 10</a> )
01/21/02	3.3	Fix table footnotes ( <a href="#">Table 9</a> , <a href="#">Table 10</a> )
05/13/02	3.4	Modify reflow time and temperature footnote ( <a href="#">Table 6</a> )
06/05/02	3.5	Corrected operating voltage (Table <Blue>)
07/03/02	3.6	Modify "Clock Operation" text, Crystal Electrical Characteristics table footnote ( <a href="#">Table 10</a> )
11/07/02	3.7	Correct figure name on page1
15-Jun-04	5.0	Reformatted; add Lead-free information; update characteristics ( <a href="#">Figure 12</a> , <a href="#">Table 6</a> , <a href="#">Table 9</a> , <Blue>)
28-Jun-2004	6	New features summary

**Please Read Carefully:**

Information in this document is provided solely in connection with ST products. STMicroelectronics NV and its subsidiaries ("ST") reserve the right to make changes, corrections, modifications or improvements, to this document, and the products and services described herein at any time, without notice.

All ST products are sold pursuant to ST's terms and conditions of sale.

Purchasers are solely responsible for the choice, selection and use of the ST products and services described herein, and ST assumes no liability whatsoever relating to the choice, selection or use of the ST products and services described herein.

No license, express or implied, by estoppel or otherwise, to any intellectual property rights is granted under this document. If any part of this document refers to any third party products or services it shall not be deemed a license grant by ST for the use of such third party products or services, or any intellectual property contained therein or considered as a warranty covering the use in any manner whatsoever of such third party products or services or any intellectual property contained therein.

**UNLESS OTHERWISE SET FORTH IN ST'S TERMS AND CONDITIONS OF SALE ST DISCLAIMS ANY EXPRESS OR IMPLIED WARRANTY WITH RESPECT TO THE USE AND/OR SALE OF ST PRODUCTS INCLUDING WITHOUT LIMITATION IMPLIED WARRANTIES OF MERCHANTABILITY, FITNESS FOR A PARTICULAR PURPOSE (AND THEIR EQUIVALENTS UNDER THE LAWS OF ANY JURISDICTION), OR INFRINGEMENT OF ANY PATENT, COPYRIGHT OR OTHER INTELLECTUAL PROPERTY RIGHT.**

**UNLESS EXPRESSLY APPROVED IN WRITING BY AN AUTHORIZED REPRESENTATIVE OF ST, ST PRODUCTS ARE NOT DESIGNED, AUTHORIZED OR WARRANTED FOR USE IN MILITARY, AIR CRAFT, SPACE, LIFE SAVING, OR LIFE SUSTAINING APPLICATIONS, NOR IN PRODUCTS OR SYSTEMS, WHERE FAILURE OR MALFUNCTION MAY RESULT IN PERSONAL INJURY, DEATH, OR SEVERE PROPERTY OR ENVIRONMENTAL DAMAGE.**

Resale of ST products with provisions different from the statements and/or technical features set forth in this document shall immediately void any warranty granted by ST for the ST product or service described herein and shall not create or extend in any manner whatsoever, any liability of ST.

ST and the ST logo are trademarks or registered trademarks of ST in various countries.

Information in this document supersedes and replaces all information previously supplied.

The ST logo is a registered trademark of STMicroelectronics. All other names are the property of their respective owners.

© 2006 STMicroelectronics - All rights reserved

STMicroelectronics group of companies

Australia - Belgium - Brazil - Canada - China - Czech Republic - Finland - France - Germany - Hong Kong - India - Israel - Italy - Japan - Malaysia - Malta - Morocco - Singapore - Spain - Sweden - Switzerland - United Kingdom - United States of America

[www.st.com](http://www.st.com)