

LMR14010A 4-V to 40-V, 1-A Step-Down Converter With High Efficiency Eco-mode™

1 Features

- Input Voltage Range: 4 V to 40 V with Transient Protection to 45 V
- 0.7-MHz Switching Frequency
- Ultra-High Efficiency at Light Load with Eco-mode™
- Low Dropout Operation
- Output Current up to 1 A
- Precision Enable Input
- Overcurrent Protection
- Internal Compensation
- Internal Soft-Start
- Small Overall Solution Size (TSOT-6L Package)
- Create a Custom Design Using the LMR14010A With the [WEBENCH® Power Designer](#)

2 Applications

- Smart Meters
- Appliances
- Elevators and Escalators
- Cameras

Simplified Schematic

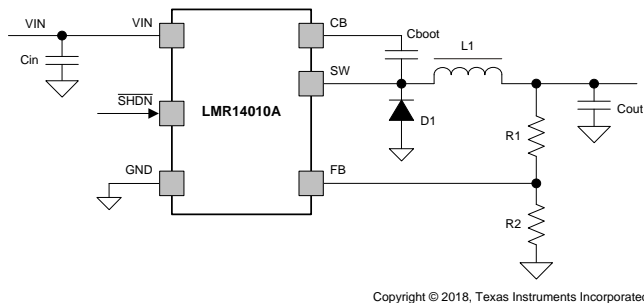

3 Description

The LMR14010A is a PWM DC-to-DC buck (step-down) regulator. With a wide input range from 4 V to 40 V, it is suitable for a wide range of applications from industrial to automotive. An ultra-low 1- μ A shutdown current prolongs battery life. Operating frequency is fixed at 0.7 MHz, allowing the use of small external components while minimizing output ripple voltage. Soft-start and compensation circuits are implemented internally, limiting the number of external components.

The LMR14010A is optimized for up to 1-A load current. It has a 0.765-V nominal feedback voltage.

The device has built-in protection features such as pulse-by-pulse current limit, thermal sensing and shutdown due to excessive power dissipation. The LMR14010A is available in a low profile TSOT-6L package (2.9 mm \times 1.6 mm \times 0.85 mm).

Device Information⁽¹⁾

PART NUMBER	PACKAGE	BODY SIZE (NOM)
LMR14010A	TSOT-6L	2.9 mm \times 1.6 mm

(1) For all available packages, see the orderable addendum at the end of the datasheet.

Efficiency vs. Current ($f_{SW} = 0.7$ MHz, $V_{IN} = 12$ V, $V_{OUT} = 3.3$ V)

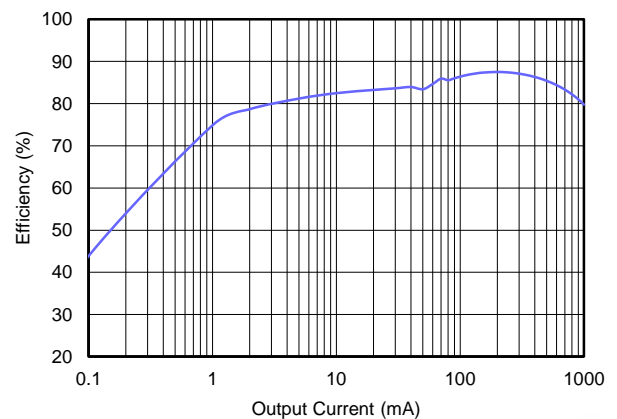

Table of Contents

1 Features	1	7.4 Device Functional Modes.....	9
2 Applications	1	8 Application and Implementation	10
3 Description	1	8.1 Application Information.....	10
4 Revision History	2	8.2 Typical Application	10
5 Pin Configuration	3	9 Power Supply Recommendations	15
6 Specifications	4	10 Layout	16
6.1 Absolute Maximum Ratings	4	10.1 Layout Guidelines	16
6.2 ESD Ratings	4	10.2 Layout Example	16
6.3 Recommended Operating Conditions.....	4	11 Device and Documentation Support	17
6.4 Thermal Information	4	11.1 Device Support	17
6.5 Electrical Characteristics.....	5	11.2 Receiving Notification of Documentation Updates	17
6.6 Typical Characteristics.....	6	11.3 Community Resources.....	17
7 Detailed Description	7	11.4 Trademarks	17
7.1 Overview	7	11.5 Electrostatic Discharge Caution.....	17
7.2 Functional Block Diagram	7	11.6 Glossary	17
7.3 Feature Description.....	8	12 Mechanical, Packaging, and Orderable Information	18

4 Revision History

NOTE: Page numbers for previous revisions may differ from page numbers in the current version.

DATE	REVISION	NOTES
March 2018	*	Initial release.

5 Pin Configuration

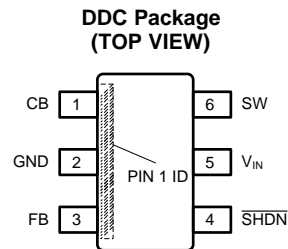

Pin Functions

PIN		I/O	DESCRIPTION
NAME	NO.		
CB	1	I	SW FET gate bias voltage. Connect C_{boot} capacitor between CB and SW.
FB	3	I	Feedback Pin. Set feedback voltage divider ratio with $V_{OUT} = V_{FB} (1+(R1/R2))$.
GND	2	G	Ground connection.
$\overline{\text{SHDN}}$	4	I	Enable and disable input pin (high voltage tolerant). Internal pull-up current source. Pull below 1.25 V to disable. Float to enable. Adjust the input undervoltage lockout with two resistors.
SW	6	O	Switch node. Connect to inductor, diode and C_{boot} capacitor.
VIN	5	I	Power input voltage pin. Input for internal supply and drain node input for internal high-side MOSFET.

6 Specifications

6.1 Absolute Maximum Ratings

Over operating free-air temperature range (unless otherwise noted) ⁽¹⁾

		MIN	MAX	UNIT
Input Voltages	V _{IN} to GND	-0.3	45	V
	$\overline{\text{SHDN}}$ to GND	-0.3	45	V
	FB to GND	-0.3	7	V
	CB to SW	-0.3	7	V
Output Voltages	SW to GND	-1	45	V
	SW to GND less than 30ns transients	-2	45	V
Storage temperature range, T _{stg}		-55	165	°C
Operating junction temperature, T _J		-0	150	°C

- (1) Stresses at or beyond those listed under “absolute maximum ratings” may cause permanent damage to the device. These are stress ratings only and functional operation of the device at these or any other conditions beyond those indicated under “recommended operating conditions” is not implied. Exposure to absolute-maximum-rated conditions for extended periods may affect device reliability.

6.2 ESD Ratings

		VALUE	UNIT
V _(ESD) Electrostatic discharge	Human-body model (HBM), per ANSI/ESDA/JEDEC JS-001 ⁽¹⁾	±1000	V
	Charged-device model (CDM), per JEDEC specification JESD22-C101 ⁽²⁾	±500	

- (1) JEDEC document JEP155 states that 500-V HBM allows safe manufacturing with a standard ESD control process. Manufacturing with less than 500-V HBM is possible with the necessary precautions.
- (2) JEDEC document JEP157 states that 250-V CDM allows safe manufacturing with a standard ESD control process. Manufacturing with less than 250-V CDM is possible with the necessary precautions.

6.3 Recommended Operating Conditions

Over operating free-air temperature range (unless otherwise noted)

		MIN	MAX	UNIT
Buck regulator	V _{in}	4	40	V
	CB		46	
	CB to SW		6	
	SW	-0.7	40	
	FB	0	5	
Control	$\overline{\text{SHDN}}$	0	40	
Temperature	Operating junction temperature, T _J	-40	125	°C

6.4 Thermal Information

THERMAL METRIC ⁽¹⁾		LMR14010A	UNIT
		SOT (DDC)	
		6 PINS	
R _{θJA}	Junction-to-ambient thermal resistance	102	°C/W
R _{θJC(top)}	Junction-to-case (top) thermal resistance	36.9	
ψ _{JB}	Junction-to-board characterization parameter	28.4	

- (1) All numbers apply for packages soldered directly onto a 3" x 3" PC board with 2 oz. copper on 4 layers in still air in accordance to JEDEC standards. Thermal resistance varies greatly with layout, copper thickness, number of layers in PCB, power distribution, number of thermal vias, board size, ambient temperature, and air flow.

6.5 Electrical Characteristics

 $V_{IN} = 12V$, $\overline{SHDN} = V_{IN}$, $T_J = 25^\circ C$, unless otherwise noted.

PARAMETER		TEST CONDITIONS	MIN	TYP	MAX	UNIT
INPUT POWER SUPPLY						
V_{IN}	Operating input voltage		4		40	V
	Shutdown supply current	EN = 0 V		1	3	μA
	Undervoltage lockout thresholds	Rising			4	V
		Falling	3			V
I_Q		ECO mode, no load, $V_{IN} = 12V$, not switching		30		μA
SHDN AND UVLO						
	Rising \overline{SHDN} Threshold Voltage		1.05	1.25	1.38	V
	\overline{SHDN} PIN current	$\overline{SHDN} = 2.3V$		-4.2		μA
		$\overline{SHDN} = 0.9V$		-1		μA
	Hysteresis current			-3		μA
HIGH-SIDE MOSFET						
	On-resistance	$V_{IN} = 12V$, CB to SW = 5.8 V		500		m Ω
t_{ON-MIN}				(1)95		ns
D_{MAX}	: Maximum duty cycle ⁽¹⁾			96%		
V_{FB}	: Feedback voltage		0.74	0.765	0.79	V
CURRENT LIMIT						
	Current limit threshold	$V_{IN} = 12V$		1500		mA
f_{SW}	Switching frequency		550	700	850	kHz
THERMAL PERFORMANCE						
$T_{SHUTDOWN}$	Thermal shutdown trip point ⁽¹⁾			170		$^\circ C$
T_{HYS}	(1)	Hysteresis		10		$^\circ C$

(1) Specified by design.

6.6 Typical Characteristics

Unless otherwise noted, $V_{IN} = 12\text{ V}$, $L = 22\ \mu\text{H}$, $C_{OUT} = 22\ \mu\text{F}$, $T_A = 25^\circ\text{C}$

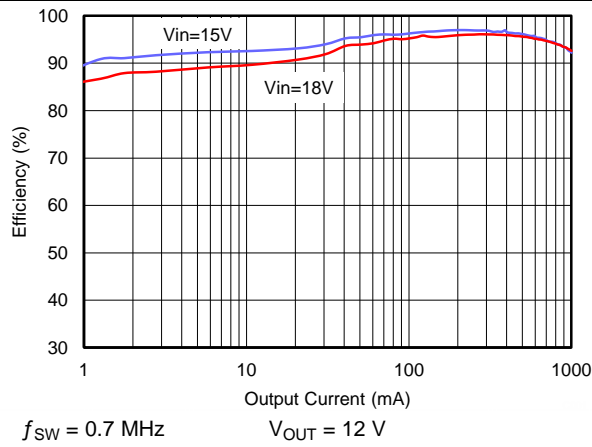

Figure 1. Efficiency vs Load Current

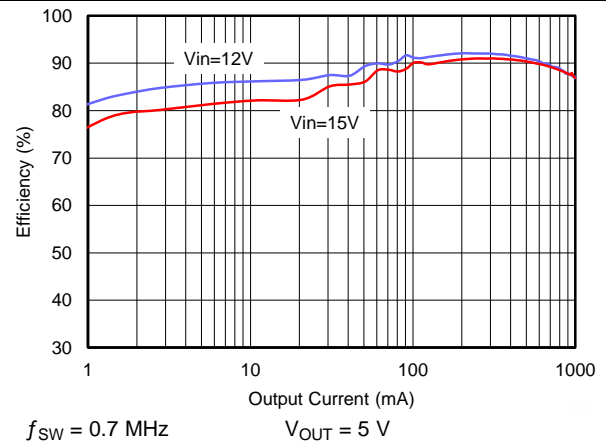

Figure 2. Efficiency vs Load Current

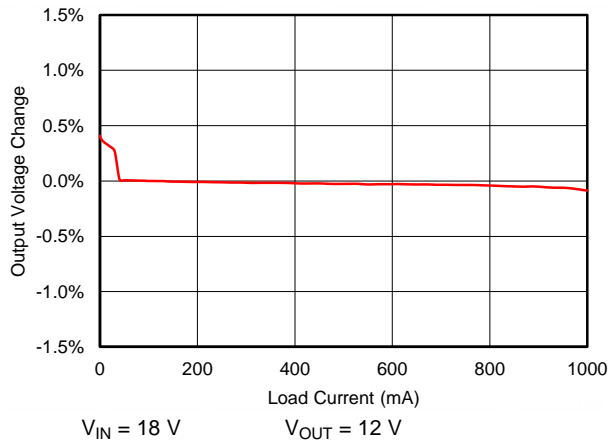

Figure 3. Load Regulation

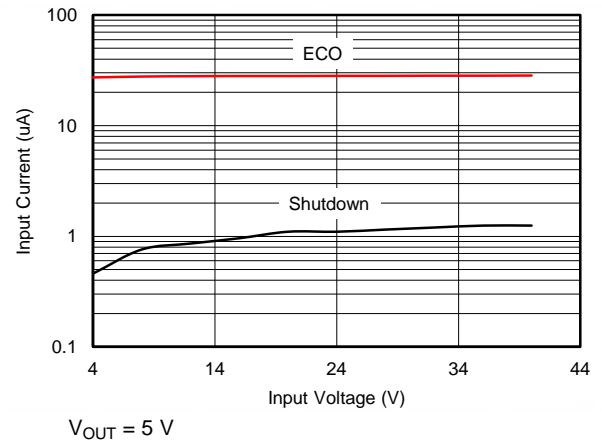

Figure 4. Supply Current vs Input Voltage (No Load)

7 Detailed Description

7.1 Overview

The LMR14010A device is a 40-V, 1-A step-down (buck) regulator. The buck regulator has a very low-quiescent current during the light load to prolong the battery life.

The LMR14010A improves performance during line and load transients by implementing a constant frequency, current mode control which reduces output capacitance and simplifies frequency compensation design. The LMR14010A reduces the external component count by integrating the boot recharge diode. The bias voltage for the integrated high-side MOSFET is supplied by a capacitor on the CB to SW pin. The boot capacitor voltage is monitored by an UVLO circuit and will turn the high side MOSFET off when the boot voltage falls below a preset threshold. The LMR14010A can operate at high duty cycles because of the boot UVLO and small refresh FET. The output voltage can be stepped down to as low as the 0.765-V reference. Internal soft start is featured to minimize inrush currents.

7.2 Functional Block Diagram

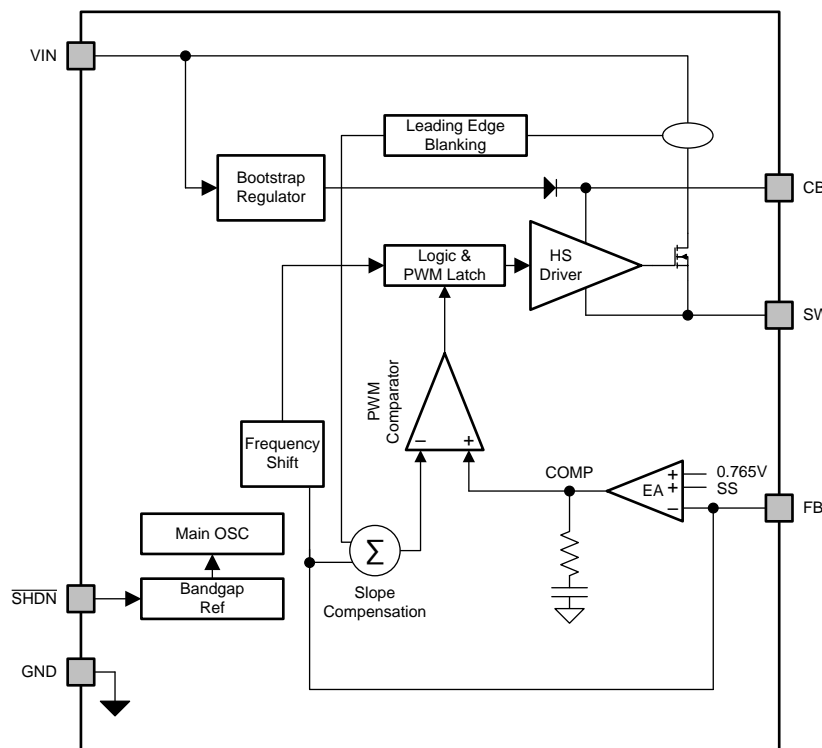

7.3 Feature Description

7.3.1 Fixed Frequency PWM Control

The LMR14010A operates at a fixed frequency, and it implements peak current mode control. The output voltage is compared through external resistors on the FB pin to an internal voltage reference by an error amplifier which drives the internal COMP node. An internal oscillator initiates the turn on of the high side power switch. The error amplifier output is compared to the high side power switch current. When the power switch current reaches the level set by the internal COMP voltage, the power switch is turned off. The internal COMP node voltage will increase and decrease as the output current increases and decreases. The device implements a current limit by clamping the COMP node voltage to a maximum level.

7.3.2 Bootstrap Voltage (CB)

The LMR14010A has an integrated boot regulator, and requires a small ceramic capacitor between the CB and SW pins to provide the gate drive voltage for the high side MOSFET. The CB capacitor is refreshed when the high side MOSFET is off and the low side diode conducts.

To improve drop out, the LMR14010A is designed to operate at 96% duty cycle as long as the CB to SW pin voltage is greater than 3.2 V. When the voltage from CB to SW drops below 3.2 V, the high-side MOSFET is turned off using an UVLO circuit which allows the low side diode to conduct and refresh the charge on the CB capacitor. Since the supply current sourced from the CB capacitor is low, the high-side MOSFET can remain on for more switching cycles than are required to refresh the capacitor, thus the effective duty cycle of the switching regulator is high.

Attention must be taken in maximum duty cycle applications with light load. To ensure SW can be pulled to ground to refresh the CB capacitor, an internal circuit will charge the CB capacitor when the load is light or the device is working in dropout condition.

7.3.3 Setting the Output Voltage

The output voltage is set using the feedback pin and a resistor divider connected to the output as shown on the front page schematic. The feedback pin voltage 0.765 V, so the ratio of the feedback resistors sets the output voltage according to the following equation: $V_{OUT} = 0.765 \text{ V} (1 + (R1/R2))$. Typically R2 will be given as 1 k Ω to 100 k Ω for a starting value. To solve for R1 given R2 and V_{OUT} uses $R1 = R2 ((V_{OUT}/0.765 \text{ V}) - 1)$.

7.3.4 Enable ($\overline{\text{SHDN}}$) and V_{IN} Undervoltage Lockout

The LMR14010A $\overline{\text{SHDN}}$ pin is a high-voltage tolerant input with an internal pull-up circuit. The device can be enabled even if the $\overline{\text{SHDN}}$ pin is floating. The regulator can also be turned on using 1.25-V or higher logic signals. If the use of a higher voltage is desired due to system or other constraints it may be used. A 100-k Ω or larger resistor is recommended between the applied voltage and the $\overline{\text{SHDN}}$ pin to protect the device. When $\overline{\text{SHDN}}$ is pulled down to 0 V, the chip is turned off and enters the lowest shutdown current mode. In shutdown mode the supply current will be decreased to approximately 1 μA . If the shutdown function is not to be used, the $\overline{\text{SHDN}}$ pin may be tied to V_{IN} . The maximum voltage to the $\overline{\text{SHDN}}$ pin should not exceed 40 V.

The LMR14010A has an internal UVLO circuit to shutdown the output if the input voltage falls below an internally fixed UVLO threshold level. This ensures that the regulator is not latched into an unknown state during low input voltage conditions. The regulator will power up when the input voltage exceeds the UVLO voltage level. If there is a requirement for a higher UVLO voltage, the $\overline{\text{SHDN}}$ can be used to adjust the input voltage UVLO by using external resistors.

7.3.5 Current Limit

The LMR14010A implements current mode control which uses the internal COMP voltage to turn off the high side MOSFET on a cycle by cycle basis. Each cycle the switch current and internal COMP voltage are compared, when the peak switch current intersects the COMP voltage, the high-side switch is turned off. During overcurrent conditions that pull the output voltage low, the error amplifier will respond by driving the COMP node high, increasing the switch current. The error amplifier output is clamped internally, which functions as a switch current limit.

Feature Description (continued)

7.3.6 Thermal Shutdown

The device implements an internal thermal shutdown to protect itself if the junction temperature exceeds 170°C typical. The thermal shutdown forces the device to stop switching when the junction temperature exceeds the thermal trip threshold. Once the junction temperature decreases below 160°C typical, the device reinitiates the power-up sequence.

7.4 Device Functional Modes

7.4.1 Continuous Conduction Mode

The LMR14010A steps the input voltage down to a lower output voltage. In continuous conduction mode (when the inductor current never reaches zero at steady state), the buck regulator operates in two cycles. The power switch is connected between VIN and SW. In the first cycle of operation the transistor is closed and the diode is reverse biased. Energy is collected in the inductor, the load current is supplied by C_{OUT} and the current through the inductor is rising. During the second cycle the transistor is open and the diode is forward biased due to the fact that the inductor current cannot instantaneously change direction. The energy stored in the inductor is transferred to the load and output capacitor. The ratio of these two cycles determines the output voltage. The output voltage is defined approximately as: $D = V_{OUT}/V_{IN}$ and $D' = (1-D)$ where D is the duty cycle of the switch, D and D' will be required for design calculations.

7.4.2 Eco-mode™

The LMR14010A operates in Eco-mode™ at light-load currents to improve efficiency by reducing switching and gate drive losses. For Eco-mode™ operation, the LMR14010A senses peak current, not average or load current, so the load current where the device enters Eco-mode™ is dependent on V_{IN}, V_{OUT} and the output inductor value. When the load current is low and the output voltage is within regulation, the device enters Eco-mode™ (see [Figure 12](#)) and draws only 28-µA input quiescent current.

8 Application and Implementation

NOTE

Information in the following applications sections is not part of the TI component specification, and TI does not warrant its accuracy or completeness. TI's customers are responsible for determining suitability of components for their purposes. Customers should validate and test their design implementation to confirm system functionality.

8.1 Application Information

The LMR14010A is a step down DC-to-DC regulator. It is typically used to convert a higher DC voltage to a lower DC voltage with a maximum output current of 1 A. The following design procedure can be used to select components for the LMR14010A. This section presents a simplified discussion of the design process.

8.2 Typical Application

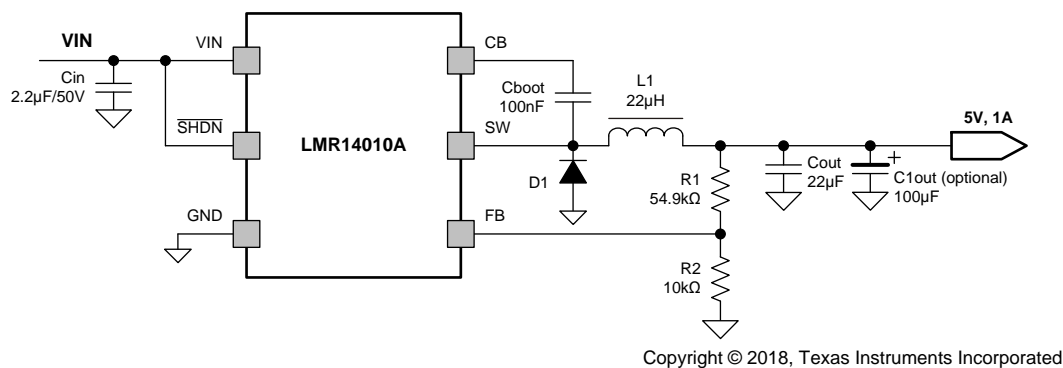

Figure 5. LMR14010A Application Circuit, 5-V Output

8.2.1 Design Requirements

8.2.1.1 Step-By-Step Design Procedure

This example details the design of a high-frequency switching regulator using ceramic output capacitors. A few parameters must be known in order to start the design process. These parameters are typically determined at the system level:

PARAMETER		VALUE
Input voltage, V_{IN}		9 V to 16 V, typical 12 V
Output voltage, V_{OUT}		5.0 V \pm 3%
Maximum output current example I_{O_max}		1 A
Minimum output current example I_{O_min}		0.1 A
Transient response 0.03 A to 0.6 A		5%
Output voltage ripple		1%
Switching frequency f_{SW}		700 kHz
Target during load transient	Overvoltage peak value	106% of output voltage
	Undervoltage value	91% of output voltage

8.2.2 Detailed Design Procedure

8.2.2.1 Custom Design With WEBENCH® Tools

[Click here](#) to create a custom design using the LMR14010A device with the WEBENCH® Power Designer.

1. Start by entering the input voltage (V_{IN}), output voltage (V_{OUT}), and output current (I_{OUT}) requirements.
2. Optimize the design for key parameters such as efficiency, footprint, and cost using the optimizer dial.
3. Compare the generated design with other possible solutions from Texas Instruments.

The WEBENCH Power Designer provides a customized schematic along with a list of materials with real-time pricing and component availability.

In most cases, these actions are available:

- Run electrical simulations to see important waveforms and circuit performance
- Run thermal simulations to understand board thermal performance
- Export customized schematic and layout into popular CAD formats
- Print PDF reports for the design, and share the design with colleagues

Get more information about WEBENCH tools at www.ti.com/WEBENCH.

8.2.2.2 Output Inductor Selection

The most critical parameters for the inductor are the inductance, peak current and the DC resistance. The inductance is related to the peak-to-peak inductor ripple current, the input and the output voltages. Since the ripple current increases with the input voltage, the maximum input voltage is always used to determine the inductance. Equation 1 is used to calculate the minimum value of the output inductor, where K_{IND} is ripple current percentage. A reasonable value is setting the ripple current to be 30% (K_{IND}) of the DC output current. For this design example, the minimum inductor value is calculated to be 16.4 μH , and a nearest standard value was chosen: 22 μH . For the output filter inductor, it is important that the RMS current and saturation current ratings not be exceeded. The RMS and peak inductor current can be found from Equation 3 and Equation 4. The inductor ripple current is 0.22 A, and the RMS current is 1 A. As the equation set demonstrates, lower ripple currents will reduce the output voltage ripple of the regulator but will require a larger value of inductance. A good starting point for most applications is 22 μH with a 1.6-A current rating. Using a rating near 1.6 A will enable the LMR14010A to current limit without saturating the inductor. This is preferable to the LMR14010A going into thermal shutdown mode and the possibility of damaging the inductor if the output is shorted to ground or other long-term overload.

$$L_{o \text{ min}} = \frac{V_{in \text{ max}} - V_{out}}{I_o \times K_{IND}} \times \frac{V_{out}}{V_{in \text{ max}} \times f_{sw}} \quad (1)$$

$$I_{ripple} = \frac{V_{out} \times (V_{in \text{ max}} - V_{out})}{V_{in \text{ max}} \times L_o \times f_{sw}} \quad (2)$$

$$I_{L-RMS} = \sqrt{I_o^2 + \frac{1}{12} I_{ripple}^2} \quad (3)$$

$$I_{L-peak} = I_o + \frac{I_{ripple}}{2} \quad (4)$$

8.2.2.3 Output Capacitor Selection

The selection of C_{OUT} is mainly driven by three primary considerations. The output capacitor will determine the modulator pole, the output voltage ripple, and how the regulator responds to a large change in load current. The output capacitance needs to be selected based on the most stringent of these three criteria.

The desired response to a large change in the load current is the first criteria. The regulator usually needs two or more clock cycles for the control loop to see the change in load current and output voltage and adjust the duty cycle to react to the change. The output capacitance must be large enough to supply the difference in current for 2 clock cycles while only allowing a tolerable amount of droop in the output voltage. Equation 5 shows the minimum output capacitance necessary to accomplish this. For this example, the transient load response is specified as a 3% change in V_{out} for a load step from 0.1 A to 1 A (full load). For this example, $\Delta I_{OUT} = 1 - 0.1 = 0.9$ A and $\Delta V_{OUT} = 0.03 \times 5 = 0.15$ V. Using these numbers gives a minimum capacitance of 17.1 μ F. For ceramic capacitors, the ESR is usually small enough to ignore in this calculation. Aluminum electrolytic and tantalum capacitors have higher ESR that should be taken into account.

The stored energy in the inductor will produce an output voltage overshoot when the load current rapidly decreases. The output capacitor must also be sized to absorb energy stored in the inductor when transitioning from a high load current to a lower load current. Equation 6 is used to calculate the minimum capacitance to keep the output voltage overshoot to a desired value. Where L is the value of the inductor, I_{OH} is the output current under heavy load, I_{OL} is the output under light load, V_f is the final peak output voltage, and V_i is the initial capacitor voltage. For this example, the worst case load step will be from 1 A to 0.1 A. The output voltage will increase during this load transition and the stated maximum in our specification is 3% of the output voltage. This will make $V_{o_overshoot} = 1.03 \times 5 = 5.15$ V. V_i is the initial capacitor voltage which is the nominal output voltage of 5 V. Using these numbers in Equation 6 yields a minimum capacitance of 14.3 μ F.

Equation 7 calculates the minimum output capacitance needed to meet the output voltage ripple specification. Where f_{sw} is the switching frequency, V_{o_ripple} is the maximum allowable output voltage ripple, and I_{L_ripple} is the inductor ripple current. Equation 7 yields 0.26 μ F.

Equation 8 calculates the maximum ESR an output capacitor can have to meet the output voltage ripple specification. Equation 8 indicates the ESR should be less than 680 m Ω . Additional capacitance de-ratings for aging, temperature and dc bias should be factored in which will increase this minimum value. For this example, 22 μ F ceramic capacitors will be used. Capacitors in the range of 4.7 μ F to 100 μ F are a good starting point with an ESR of 0.7 Ω or less.

$$C_{out} > \frac{2 \times \Delta I_{out}}{f_{sw} \times \Delta V_{out}} \quad (5)$$

$$C_{out} > L_o \times \frac{(I_{oh}^2 - I_{ol}^2)}{(V_f^2 - V_i^2)} \quad (6)$$

$$C_{out} > \frac{1}{8 \times f_{sw}} \times \frac{1}{\frac{V_{o_ripple}}{I_{L_ripple}}} \quad (7)$$

$$R_{ESR} < \frac{V_{o_ripple}}{I_{L_ripple}} \quad (8)$$

8.2.2.4 Schottky Diode Selection

The breakdown voltage rating of the diode is preferred to be 25% higher than the maximum input voltage. In the target application, the current rating for the diode should be equal to the maximum output current for best reliability in most applications. In cases where the input voltage is not much greater than the output voltage the average diode current is lower. In this case it is possible to use a diode with a lower average current rating, approximately $(1-D) \times I_{OUT}$, however the peak current rating should be higher than the maximum load current. A 1-A to 2-A rated diode is a good starting point.

8.2.2.5 Input Capacitor Selection

A low ESR ceramic capacitor is needed between the VIN pin and ground pin. This capacitor prevents large voltage transients from appearing at the input. Use a 1-μF to 10-μF value with X5R or X7R dielectric. Depending on construction, a ceramic capacitor's value can decrease up to 50% of its nominal value when rated voltage is applied. Consult with the capacitor manufacturer's data sheet for information on capacitor derating over voltage and temperature. The capacitor must also have a ripple current rating greater than the maximum input current ripple of the LMR14010A. The input ripple current can be calculated using below Equations.

For this example design, one 2.2-μF, 50-V capacitor is selected. The input capacitance value determines the input ripple voltage of the regulator. The input voltage ripple can be calculated using Equation 10. Using the design example values, $I_{OUTMAX} = 1$ A, $C_{IN} = 2.2$ μF, $f_{SW} = 700$ kHz, yields an input voltage ripple of 162 mV and an rms input ripple current of 0.5 A.

$$I_{cirms} = I_{out} \times \sqrt{\frac{V_{out}}{V_{in\ min}} \times \frac{(V_{in\ min} - V_{out})}{V_{in\ min}}} \quad (9)$$

$$\Delta V_{in} = \frac{I_{out\ max} \times 0.25}{C_{in} \times f_{sw}} \quad (10)$$

8.2.2.6 Bootstrap Capacitor Selection

A 0.1-μF ceramic capacitor or larger is recommended for the bootstrap capacitor (C_{boot}). For applications where the input voltage is close to output voltage a larger capacitor is recommended, generally 0.1 μF to 1 μF to ensure plenty of gate drive for the internal switches and a consistently low $R_{DS(ON)}$. A ceramic capacitor with an X7R or X5R grade dielectric with a voltage rating of 10 V or higher is recommended because of the stable characteristics over temperature and voltage.

Below are the recommended typical output voltage inductor/capacitor combinations for optimized total solution size.

P/N	V _{OUT} (V)	R1 (kΩ)	R2 (kΩ)	L (μH)	C _{OUT} (μF)
LMR14010A	5	54.9 (1%)	10 (1%)	22	22
LMR14010A	5.7	64.9 (1%)	10 (1%)	22	22
LMR14010A	12	147 (1%)	10 (1%)	22	10

8.2.3 Application Performance Curves

Unless otherwise noted, $V_{IN} = 12\text{ V}$, $L = 22\ \mu\text{H}$, $C_{OUT} = 22\ \mu\text{F}$, $T_A = 25^\circ\text{C}$

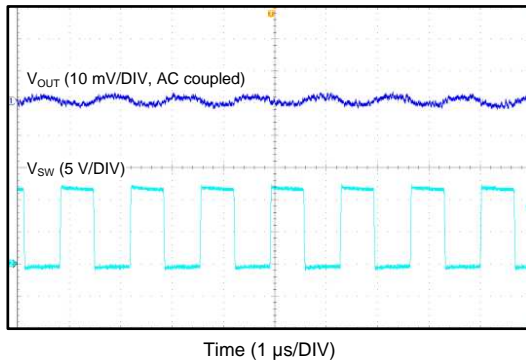

Figure 6. Switching Node and Output Voltage Waveform ($V_{IN} = 12\text{ V}$, $V_{OUT} = 5\text{ V}$, $I_{Load} = 1\text{ A}$)

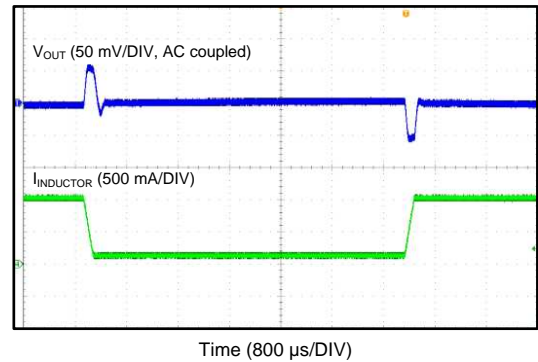

Figure 7. Load Transient Between 0.1 A and 1 A ($V_{IN} = 12\text{ V}$, $V_{OUT} = 5\text{ V}$)

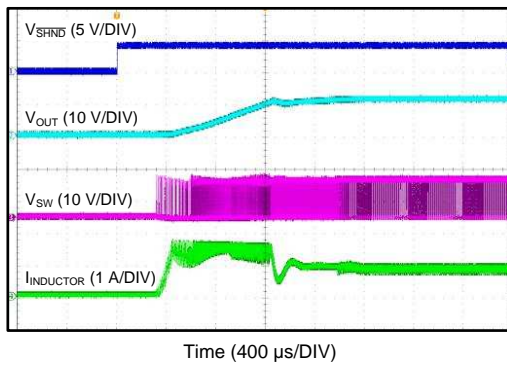

Figure 8. Start-up Waveform ($V_{IN} = 18\text{ V}$, $V_{OUT} = 12\text{ V}$, $I_{Load} = 800\text{ mA}$)

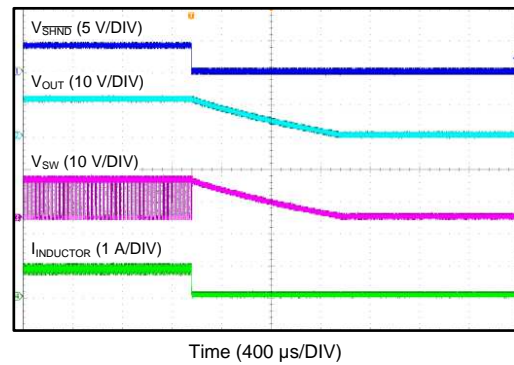

Figure 9. Shutdown Waveform ($V_{IN} = 18\text{ V}$, $V_{OUT} = 12\text{ V}$, $I_{Load} = 800\text{ mA}$)

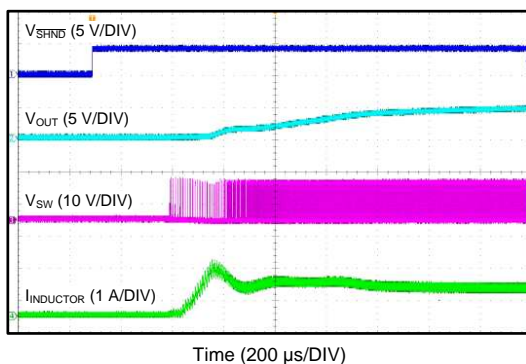

Figure 10. Start-Up Waveform ($V_{IN} = 12\text{ V}$, $V_{OUT} = 5\text{ V}$, $I_{Load} = 800\text{ mA}$)

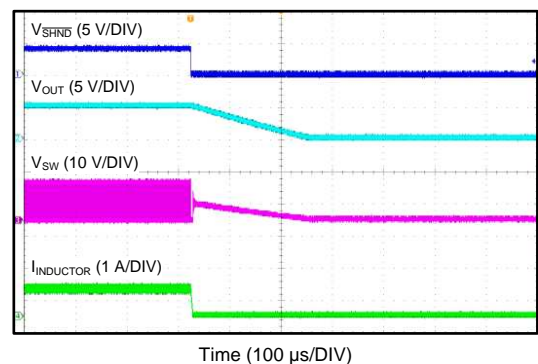
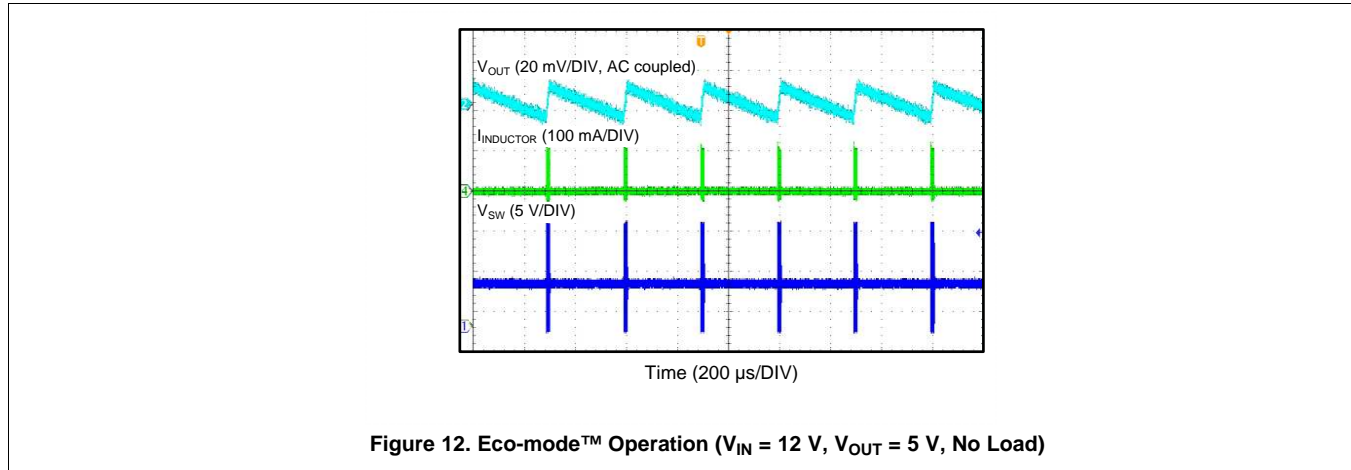

Figure 11. Shutdown Waveform ($V_{IN} = 12\text{ V}$, $V_{OUT} = 5\text{ V}$, $I_{Load} = 800\text{ mA}$)

Unless otherwise noted, $V_{IN} = 12\text{ V}$, $L = 22\ \mu\text{H}$, $C_{OUT} = 22\ \mu\text{F}$, $T_A = 25^\circ\text{C}$



9 Power Supply Recommendations

The LMR14010A is designed to operate from an input voltage supply range between 4 V and 40 V. This input supply should be able to withstand the maximum input current and maintain a voltage above 4 V. The resistance of the input supply rail should be low enough that an input current transient does not cause a high enough drop at the LMR14010A supply voltage that can cause a false UVLO fault triggering and system reset. If the input supply is located more than a few inches from the LMR14010A, additional bulk capacitance may be required in addition to the ceramic input capacitors.

11 Device and Documentation Support

11.1 Device Support

11.1.1 Development Support

11.1.1.1 Custom Design With WEBENCH® Tools

Click [here](#) to create a custom design using the LMR14010A device with the WEBENCH® Power Designer.

1. Start by entering the input voltage (V_{IN}), output voltage (V_{OUT}), and output current (I_{OUT}) requirements.
2. Optimize the design for key parameters such as efficiency, footprint, and cost using the optimizer dial.
3. Compare the generated design with other possible solutions from Texas Instruments.

The WEBENCH Power Designer provides a customized schematic along with a list of materials with real-time pricing and component availability.

In most cases, these actions are available:

- Run electrical simulations to see important waveforms and circuit performance
- Run thermal simulations to understand board thermal performance
- Export customized schematic and layout into popular CAD formats
- Print PDF reports for the design, and share the design with colleagues

Get more information about WEBENCH tools at www.ti.com/WEBENCH.

11.2 Receiving Notification of Documentation Updates

To receive notification of documentation updates, navigate to the device product folder on ti.com. In the upper right corner, click on *Alert me* to register and receive a weekly digest of any product information that has changed. For change details, review the revision history included in any revised document.

11.3 Community Resources

The following links connect to TI community resources. Linked contents are provided "AS IS" by the respective contributors. They do not constitute TI specifications and do not necessarily reflect TI's views; see TI's [Terms of Use](#).

TI E2E™ Online Community *TI's Engineer-to-Engineer (E2E) Community*. Created to foster collaboration among engineers. At e2e.ti.com, you can ask questions, share knowledge, explore ideas and help solve problems with fellow engineers.

Design Support *TI's Design Support* Quickly find helpful E2E forums along with design support tools and contact information for technical support.

11.4 Trademarks

Eco-mode, E2E are trademarks of Texas Instruments.
WEBENCH is a registered trademark of Texas Instruments.

11.5 Electrostatic Discharge Caution



This integrated circuit can be damaged by ESD. Texas Instruments recommends that all integrated circuits be handled with appropriate precautions. Failure to observe proper handling and installation procedures can cause damage.

ESD damage can range from subtle performance degradation to complete device failure. Precision integrated circuits may be more susceptible to damage because very small parametric changes could cause the device not to meet its published specifications.

11.6 Glossary

SLYZ022 — *TI Glossary*.

This glossary lists and explains terms, acronyms, and definitions.

12 Mechanical, Packaging, and Orderable Information

The following pages include mechanical, packaging, and orderable information. This information is the most current data available for the designated devices. This data is subject to change without notice and revision of this document. For browser-based versions of this data sheet, refer to the left-hand navigation.

PACKAGING INFORMATION

Orderable Device	Status (1)	Package Type	Package Drawing	Pins	Package Qty	Eco Plan (2)	Lead/Ball Finish (6)	MSL Peak Temp (3)	Op Temp (°C)	Device Marking (4/5)	Samples
LMR14010ADDCR	PREVIEW	SOT-23-THIN	DDC	6	3000	Green (RoHS & no Sb/Br)	CU NIPDAU	Level-1-260C-UNLIM	-40 to 125	1N72	
LMR14010ADDCCT	PREVIEW	SOT-23-THIN	DDC	6	250	Green (RoHS & no Sb/Br)	CU NIPDAU	Level-1-260C-UNLIM	-40 to 125	1N72	

(1) The marketing status values are defined as follows:

ACTIVE: Product device recommended for new designs.

LIFEBUY: TI has announced that the device will be discontinued, and a lifetime-buy period is in effect.

NRND: Not recommended for new designs. Device is in production to support existing customers, but TI does not recommend using this part in a new design.

PREVIEW: Device has been announced but is not in production. Samples may or may not be available.

OBSOLETE: TI has discontinued the production of the device.

(2) **RoHS:** TI defines "RoHS" to mean semiconductor products that are compliant with the current EU RoHS requirements for all 10 RoHS substances, including the requirement that RoHS substance do not exceed 0.1% by weight in homogeneous materials. Where designed to be soldered at high temperatures, "RoHS" products are suitable for use in specified lead-free processes. TI may reference these types of products as "Pb-Free".

RoHS Exempt: TI defines "RoHS Exempt" to mean products that contain lead but are compliant with EU RoHS pursuant to a specific EU RoHS exemption.

Green: TI defines "Green" to mean the content of Chlorine (Cl) and Bromine (Br) based flame retardants meet JS709B low halogen requirements of <=1000ppm threshold. Antimony trioxide based flame retardants must also meet the <=1000ppm threshold requirement.

(3) MSL, Peak Temp. - The Moisture Sensitivity Level rating according to the JEDEC industry standard classifications, and peak solder temperature.

(4) There may be additional marking, which relates to the logo, the lot trace code information, or the environmental category on the device.

(5) Multiple Device Markings will be inside parentheses. Only one Device Marking contained in parentheses and separated by a "~" will appear on a device. If a line is indented then it is a continuation of the previous line and the two combined represent the entire Device Marking for that device.

(6) Lead/Ball Finish - Orderable Devices may have multiple material finish options. Finish options are separated by a vertical ruled line. Lead/Ball Finish values may wrap to two lines if the finish value exceeds the maximum column width.

Important Information and Disclaimer:The information provided on this page represents TI's knowledge and belief as of the date that it is provided. TI bases its knowledge and belief on information provided by third parties, and makes no representation or warranty as to the accuracy of such information. Efforts are underway to better integrate information from third parties. TI has taken and continues to take reasonable steps to provide representative and accurate information but may not have conducted destructive testing or chemical analysis on incoming materials and chemicals. TI and TI suppliers consider certain information to be proprietary, and thus CAS numbers and other limited information may not be available for release.

In no event shall TI's liability arising out of such information exceed the total purchase price of the TI part(s) at issue in this document sold by TI to Customer on an annual basis.

DDC (R-PDSO-G6)

PLASTIC SMALL-OUTLINE

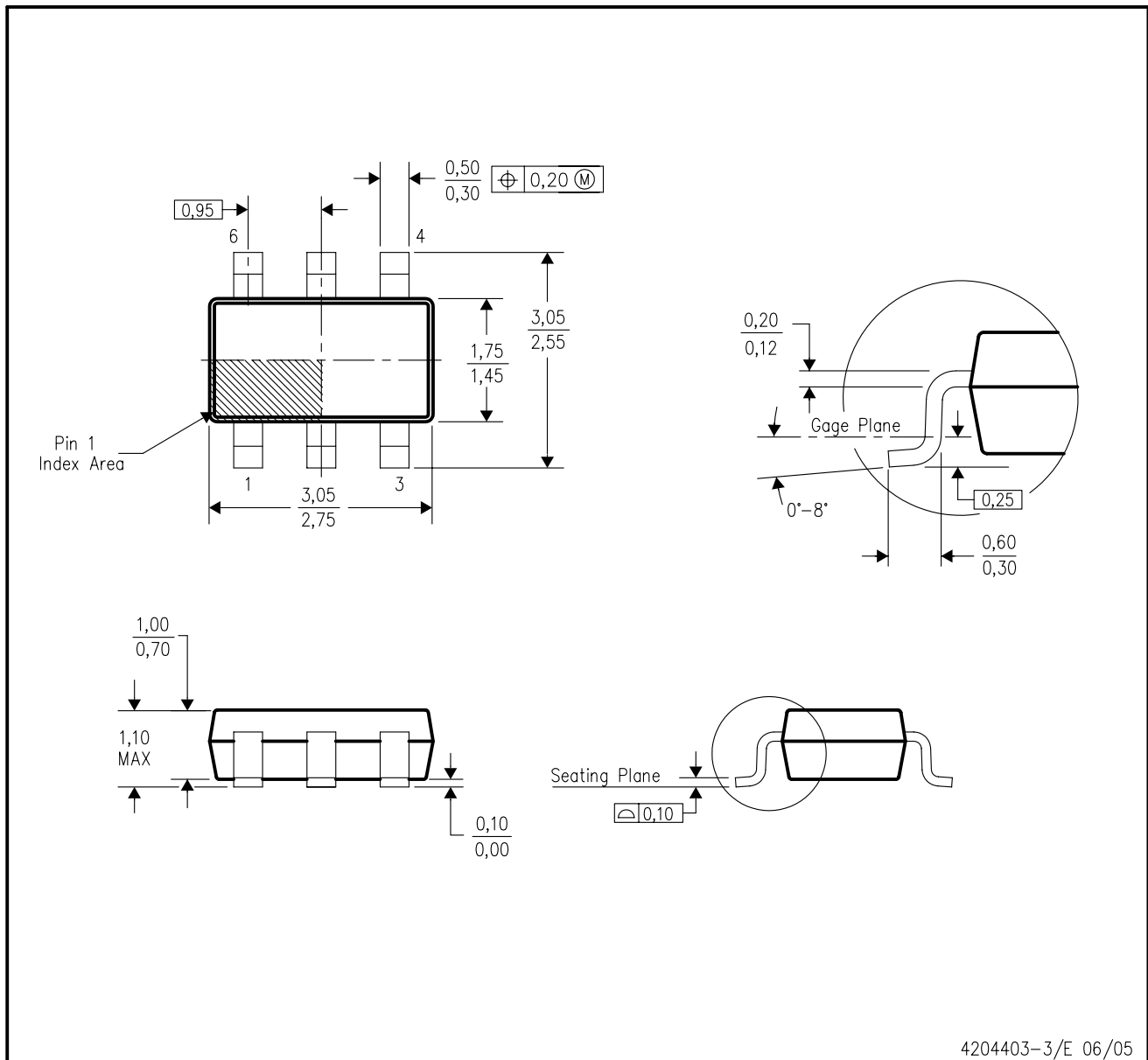

- NOTES:
- All linear dimensions are in millimeters.
 - This drawing is subject to change without notice.
 - Body dimensions do not include mold flash or protrusion.
 - Falls within JEDEC MO-193 variation AA (6 pin).

DDC (R-PDSO-G6)

PLASTIC SMALL OUTLINE

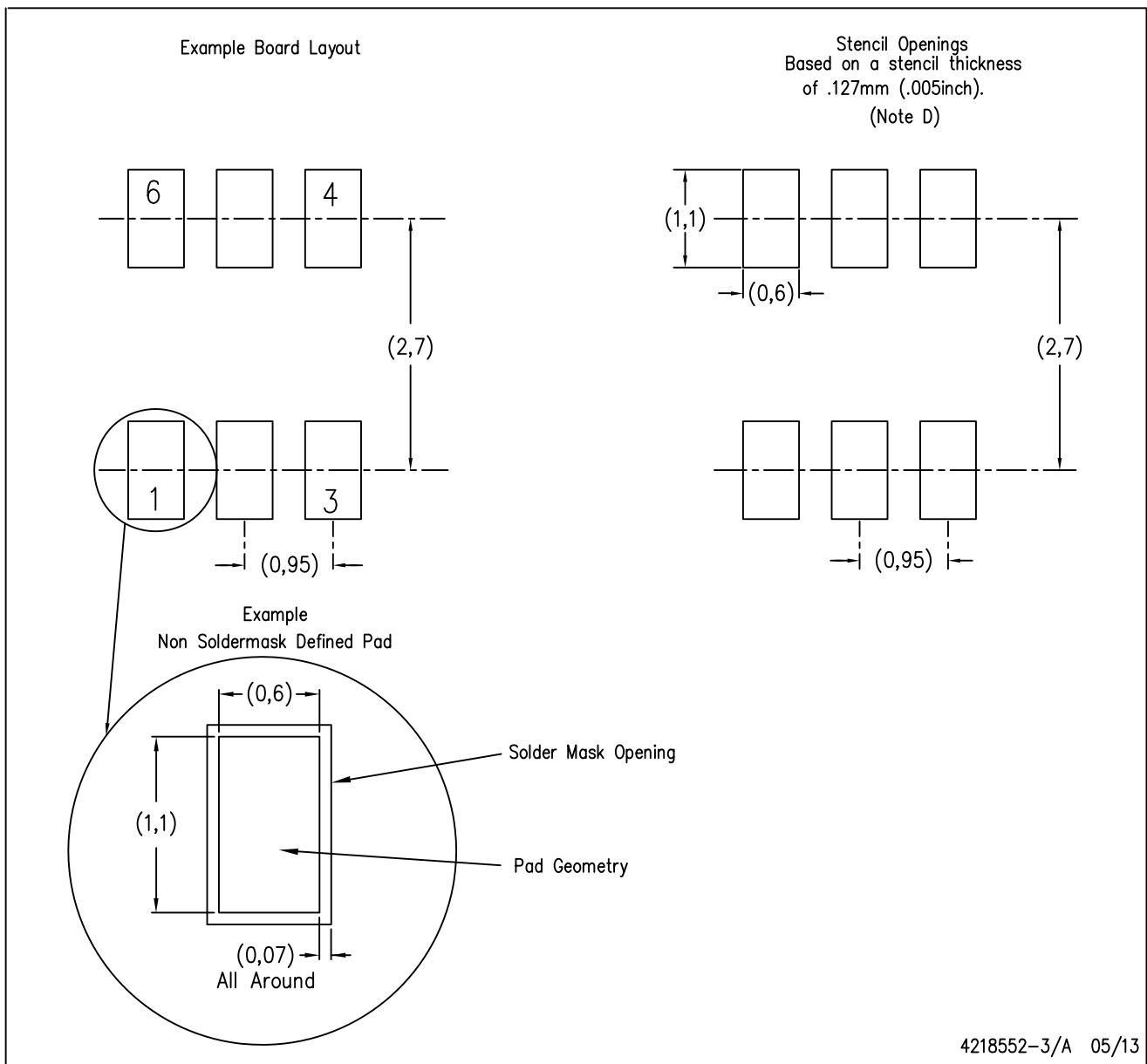

- NOTES:
- A. All linear dimensions are in millimeters.
 - B. This drawing is subject to change without notice.
 - C. Publication IPC-7351 is recommended for alternate designs.
 - D. Laser cutting apertures with trapezoidal walls and also rounding corners will offer better paste release. Customers should contact their board assembly site for stencil design recommendations. Example stencil design based on a 50% volumetric metal load solder paste. Refer to IPC-7525 for other stencil recommendations.

IMPORTANT NOTICE

Texas Instruments Incorporated (TI) reserves the right to make corrections, enhancements, improvements and other changes to its semiconductor products and services per JESD46, latest issue, and to discontinue any product or service per JESD48, latest issue. Buyers should obtain the latest relevant information before placing orders and should verify that such information is current and complete.

TI's published terms of sale for semiconductor products (<http://www.ti.com/sc/docs/stdterms.htm>) apply to the sale of packaged integrated circuit products that TI has qualified and released to market. Additional terms may apply to the use or sale of other types of TI products and services.

Reproduction of significant portions of TI information in TI data sheets is permissible only if reproduction is without alteration and is accompanied by all associated warranties, conditions, limitations, and notices. TI is not responsible or liable for such reproduced documentation. Information of third parties may be subject to additional restrictions. Resale of TI products or services with statements different from or beyond the parameters stated by TI for that product or service voids all express and any implied warranties for the associated TI product or service and is an unfair and deceptive business practice. TI is not responsible or liable for any such statements.

Buyers and others who are developing systems that incorporate TI products (collectively, "Designers") understand and agree that Designers remain responsible for using their independent analysis, evaluation and judgment in designing their applications and that Designers have full and exclusive responsibility to assure the safety of Designers' applications and compliance of their applications (and of all TI products used in or for Designers' applications) with all applicable regulations, laws and other applicable requirements. Designer represents that, with respect to their applications, Designer has all the necessary expertise to create and implement safeguards that (1) anticipate dangerous consequences of failures, (2) monitor failures and their consequences, and (3) lessen the likelihood of failures that might cause harm and take appropriate actions. Designer agrees that prior to using or distributing any applications that include TI products, Designer will thoroughly test such applications and the functionality of such TI products as used in such applications.

TI's provision of technical, application or other design advice, quality characterization, reliability data or other services or information, including, but not limited to, reference designs and materials relating to evaluation modules, (collectively, "TI Resources") are intended to assist designers who are developing applications that incorporate TI products; by downloading, accessing or using TI Resources in any way, Designer (individually or, if Designer is acting on behalf of a company, Designer's company) agrees to use any particular TI Resource solely for this purpose and subject to the terms of this Notice.

TI's provision of TI Resources does not expand or otherwise alter TI's applicable published warranties or warranty disclaimers for TI products, and no additional obligations or liabilities arise from TI providing such TI Resources. TI reserves the right to make corrections, enhancements, improvements and other changes to its TI Resources. TI has not conducted any testing other than that specifically described in the published documentation for a particular TI Resource.

Designer is authorized to use, copy and modify any individual TI Resource only in connection with the development of applications that include the TI product(s) identified in such TI Resource. NO OTHER LICENSE, EXPRESS OR IMPLIED, BY ESTOPPEL OR OTHERWISE TO ANY OTHER TI INTELLECTUAL PROPERTY RIGHT, AND NO LICENSE TO ANY TECHNOLOGY OR INTELLECTUAL PROPERTY RIGHT OF TI OR ANY THIRD PARTY IS GRANTED HEREIN, including but not limited to any patent right, copyright, mask work right, or other intellectual property right relating to any combination, machine, or process in which TI products or services are used. Information regarding or referencing third-party products or services does not constitute a license to use such products or services, or a warranty or endorsement thereof. Use of TI Resources may require a license from a third party under the patents or other intellectual property of the third party, or a license from TI under the patents or other intellectual property of TI.

TI RESOURCES ARE PROVIDED "AS IS" AND WITH ALL FAULTS. TI DISCLAIMS ALL OTHER WARRANTIES OR REPRESENTATIONS, EXPRESS OR IMPLIED, REGARDING RESOURCES OR USE THEREOF, INCLUDING BUT NOT LIMITED TO ACCURACY OR COMPLETENESS, TITLE, ANY EPIDEMIC FAILURE WARRANTY AND ANY IMPLIED WARRANTIES OF MERCHANTABILITY, FITNESS FOR A PARTICULAR PURPOSE, AND NON-INFRINGEMENT OF ANY THIRD PARTY INTELLECTUAL PROPERTY RIGHTS. TI SHALL NOT BE LIABLE FOR AND SHALL NOT DEFEND OR INDEMNIFY DESIGNER AGAINST ANY CLAIM, INCLUDING BUT NOT LIMITED TO ANY INFRINGEMENT CLAIM THAT RELATES TO OR IS BASED ON ANY COMBINATION OF PRODUCTS EVEN IF DESCRIBED IN TI RESOURCES OR OTHERWISE. IN NO EVENT SHALL TI BE LIABLE FOR ANY ACTUAL, DIRECT, SPECIAL, COLLATERAL, INDIRECT, PUNITIVE, INCIDENTAL, CONSEQUENTIAL OR EXEMPLARY DAMAGES IN CONNECTION WITH OR ARISING OUT OF TI RESOURCES OR USE THEREOF, AND REGARDLESS OF WHETHER TI HAS BEEN ADVISED OF THE POSSIBILITY OF SUCH DAMAGES.

Unless TI has explicitly designated an individual product as meeting the requirements of a particular industry standard (e.g., ISO/TS 16949 and ISO 26262), TI is not responsible for any failure to meet such industry standard requirements.

Where TI specifically promotes products as facilitating functional safety or as compliant with industry functional safety standards, such products are intended to help enable customers to design and create their own applications that meet applicable functional safety standards and requirements. Using products in an application does not by itself establish any safety features in the application. Designers must ensure compliance with safety-related requirements and standards applicable to their applications. Designer may not use any TI products in life-critical medical equipment unless authorized officers of the parties have executed a special contract specifically governing such use. Life-critical medical equipment is medical equipment where failure of such equipment would cause serious bodily injury or death (e.g., life support, pacemakers, defibrillators, heart pumps, neurostimulators, and implantables). Such equipment includes, without limitation, all medical devices identified by the U.S. Food and Drug Administration as Class III devices and equivalent classifications outside the U.S.

TI may expressly designate certain products as completing a particular qualification (e.g., Q100, Military Grade, or Enhanced Product). Designers agree that it has the necessary expertise to select the product with the appropriate qualification designation for their applications and that proper product selection is at Designers' own risk. Designers are solely responsible for compliance with all legal and regulatory requirements in connection with such selection.

Designer will fully indemnify TI and its representatives against any damages, costs, losses, and/or liabilities arising out of Designer's non-compliance with the terms and provisions of this Notice.